

**Valuable goods** Why patents are vital for the quantum economy

**Meeting of minds** What went on at the Global Physics Summit

**Lunar journey** Artemis II returns astronauts to the Moon



## Caffeine fix

How physics can improve your coffee

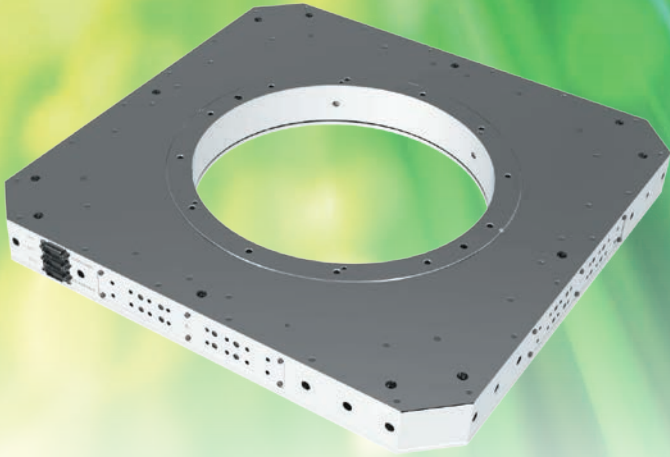

Ultra-stable and high-precision positioning for wafer-masks in the 300 mm manufacturing process.

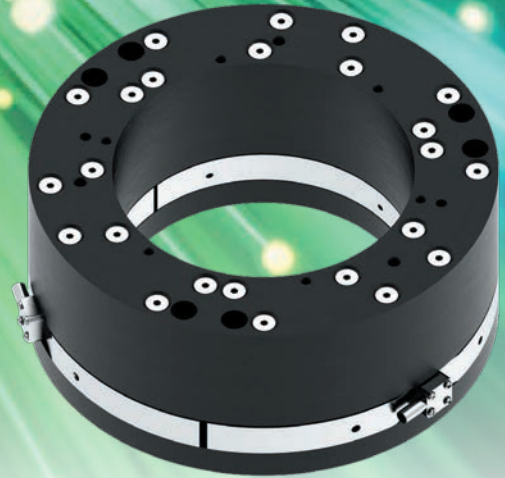

High-dynamic positioning of large objectives and optics with masses of up to 8 kg.

## Innovative high-precision nanopositioning solutions for disruptive technologies



Queensgate develops enabling technologies for:

- The next generation of semiconductors and micro OLED devices.
- Large-scale data centers for cloud computing and artificial intelligence.
- Photonics: quantum computing, quantum sensing, 5G & fiber optic communication.
- Advancements in life science and therapeutics.

Get in touch: +49 (0) 3641 242 010 | +44 (0) 1223 881 711 | [inquiries@prior.com](mailto:inquiries@prior.com)

**Leaders in piezo nanopositioning since 1979**

# physicsworld

Volume 39 No 6

Institute of Physics



7

KSS

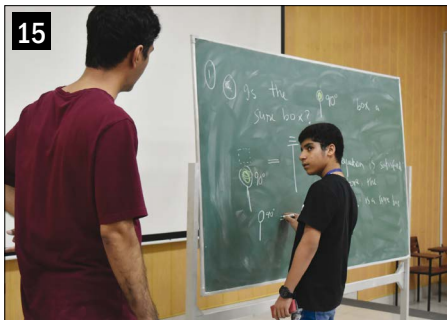

15

MSA



30

Tim Meyer/ Colorado School of Mines



50

## 45 On the cover

Caffeine fix: how physics can improve your coffee. (Courtesy: iStock/Evrymmnt)

## Welcome Back to the Moon 3

*Matin Durrani* introduces the June issue of *Physics World*

## Interview Setting the course for physics 7

New Institute of Physics president *Paul Howarth* explains why communicating the relevance of physics to society has never been more important

## Analysis Exam board fined for 'serious errors' 9

The exam board Cambridge OCR has been fined £270 000 for errors in A- and AS-level physics exam papers, as *Michael Banks* reports

## Transactions Why patents are so vital for the quantum economy 11

*Mark Saunders* on how intellectual property is crucial for quantum technology

## Forum Quantum through pictures 15

*Muhammad Sabieh Anwar* describes a new way to engage students in quantum physics

## Critical Point The strange metaphor of Euglena's tail 19

*Robert P Crease* and *Gino Elia* unpick the strange "QBism" interpretation of quantum mechanics

## Review The dark side of lithium batteries 23

*James Dacey* reviews *The Elements of Power: a Story of War, Technology and the Dirtiest Supply Chain on Earth* by Nicolas Niarchos

## Feedback 27

Readers' letters on nuclear energy, mentoring and glassblowing

## Feature Artemis II returns humanity to the Moon 30

NASA's Artemis II lunar mission gripped the world with excitement and curiosity. *Keith Cooper* follows the mission's journey and looks at what comes next for humans in space

## Feature A critical mass of physics talent 38

*Candice Chua* and *Margaret Harris* report from the American Physical Society's Global Physics Summit – billed as the world's biggest physics meeting – while *Victoria Merriman* describes her experiences at an official satellite event in Cameroon

## Feature Coffee with a splash of physics 45

With climate change impacting the world's coffee supplies, can physics help you reduce waste by brewing smarter? *Michael Allen* investigates

## Careers Building up the quantum workforce 50

Colorado School of Mines' *Frédéric Sarazin* on a new undergraduate route into quantum engineering

## Careers Ask me anything 54

*Ian Griffiths* – "While changing jobs is a daunting task, it has always been worthwhile"

## Recruitment 55

The latest job vacancies, courses and calls for proposals

## Lateral Thoughts Jumping knots and pointed tips 60

*Michael Banks* picks his favourite stories and quotes from the weird and wonderful world of physics

**EXCITE IT.** WRITE IT. **INSPECT IT.** DETECT IT.  
*ILLUMINATE IT.* **TRAP IT.** REVEAL IT. **COOL IT.**  
**MEASURE IT.** *PATTERN IT.* **LOCK IT.** *MAP IT.*  
**PUMP IT.** PROBE IT. *SCAN IT.* INTERROGATE IT.  
*ACTIVATE IT.* **CHARACTERISE IT.** RESOLVE IT.  
*IMAGE IT.* CONVERT IT. REPUMP IT. *SHIFT IT.*  
**STIMULATE IT.** SEE IT. SCATTER IT. SWEEP IT.  
ANALYSE IT. **ENTANGLE IT.** SATURATE IT. **ENGAGE IT.**  
**ISOLATE IT.** TWEEZE IT. STABILISE IT. *FIND IT.*  
**OBSERVE IT.** CALIBRATE IT. **QUANTIFY IT.**

Do it all with | **Skylark Lasers** 

Replace your complex ECDL + TA  
+ filtering + locking chain with a single box.

**780 nm**    **$M^2 \leq 1.1$**    **TEM<sub>00</sub>**

**Free space power up to 500 mW**

**Mode-hop-free operation**

**Low noise, long term stable output**

Onboard automatic spectroscopic  
lock to Rubidium hyperfine  
transitions now available.



View specifications

**Skylark Lasers** 

Single frequency CW DPSS laser systems

skylarklasers.com

## Back to the Moon

The success of NASA's Artemis II mission makes recent cuts to UK space science and astronomy seem perverse and penny-pinching



The wonderful image you're looking at above was taken in early April by astronauts on board NASA's Artemis II mission. It shows the crescent Earth slipping gracefully behind the limb of the Moon as the *Integrity* spacecraft prepares to loop around the far side of our nearest neighbour. The image evokes memories of the famous "Earthrise" photo taken by Apollo 8 astronauts back in 1968.

As Keith Cooper describes (see pp30–36), Artemis II took astronauts farther from our planet than any human has ever gone. Sure, they didn't walk on the lunar surface – the last person to do so was Eugene Cernan in 1972 – but the mission could lead to NASA building a permanently crewed outpost at the Moon's south pole. Thanks to online communication, the Artemis II astronauts were also able to share their own excitement directly with millions of people watching from Earth.

### Striking a balance

The huge positive impact of Artemis II on the public's consciousness makes current funding cuts to astronomy, space science and particle physics in the UK all the more perverse and frustrating. The cuts are part of a reprioritization of activities at UK Research and Innovation (UKRI) – the umbrella body for the UK's research councils. Overall UKRI funding is static at £38.6bn over the four years to 2030, with some areas such as quantum physics and AI set to gain money. But that will be cold comfort to those facing cuts.

Targeting particle physics, space science and astronomy isn't great PR for physics either. We know that those fields attract newcomers into the subject – and once they are hooked, there's a pipeline of talented people who can go into other areas, industry or engineering. The cuts also undermine the international image of UK physics, making the country appear an unreliable partner in big-science projects.

Responding to the cuts to UK physics is one of the priorities for new Institute of Physics (IOP) president Paul Howarth, who studied physics at the University of Birmingham, before spending most of his career in the nuclear industry. As you can find out in an interview with Howarth (see pp7–8), the IOP has to strike a balance between celebrating new and exciting areas on the one hand and protecting threatened fields on the other.

### Coffee, with a splash of physics

Finally, if you're sipping a coffee while reading *Physics World*, you might be wondering why your caffeine fix has shot up in price. One big reason is climate change, which is disrupting coffee production, lowering yields and raising costs. Fortunately, physicists who study coffee (yes, they get everywhere) have found a clever way to get the same taste from fewer grounds. Find out more about the physics of coffee in Michael Allen's feature (see pp45–49) and test your knowledge in a fun interactive crossword ([tinyurl.com/363pyr9f](https://tinyurl.com/363pyr9f))

**Matin Durrani**, editor-in-chief, *Physics World*



**APCs waived  
until 2027!**

# PRX Intelligence

*PRX Intelligence* is a new open-access journal from APS for high-impact research at the intersection of physics and machine intelligence. It publishes rigorous, innovative work where AI, machine learning, and data science deepen our understanding of physical systems and scientific discovery.



**Now open for submissions**  
[go.aps.org/prxi](https://go.aps.org/prxi)

PUBLISHED BY



## Publishing team

**Head of media** Jo Allen

**Editor-in-chief** Martin Durrani

**News editor** Michael Banks

**Features editors** Tushna Commissariat, Sarah Tesh

**Online editors** Tami Freeman, Margaret Harris, Hamish Johnston

**Product and marketing** Laura Gillham

**Content and production** Kate Gardner, Kyla Rushman

**Technical illustrations** Alison Tovey

**Circulation** Alison Gardiner

**Advertisement sales** Edward Jost

**Advertisement production** Katie Graham

## How to receive Physics World

*Physics World* is available on an individual basis, worldwide, through membership of the Institute of Physics. *Physics World* is published monthly as 12 issues per annual volume by IOP Publishing Ltd.

The 2026 subscription rate for institutions is £1066 for the current year and electronic archive. Orders to: Subscriptions Dept, IOP Publishing, No.2 The Distillery, Glassfields, Avon Street, Bristol BS2 0GR, UK; tel +44 (0)117 929 7481; e-mail [customerservices@iopublishing.org](mailto:customerservices@iopublishing.org).

## IOP Publishing

IOP Publishing Ltd permits single photocopying of single articles for private study or research, irrespective of where the copying is done. Multiple copying of contents or parts thereof without permission is in breach of copyright, except in the UK under the terms of the agreement between the CVCP and the CLA. Authorization of photocopy items for internal or personal use, or the internal or personal use of specific clients, is granted by IOP Publishing Ltd for libraries and other users registered with the Copyright Clearance Center (CCC) Transactional Reporting Service, provided that the base fee of \$2.50 per copy is paid directly to CCC, 27 Congress Street, Salem, MA 01970, USA

Printed in the UK by Warners (Midlands) plc, The Maltings, West Street, Bourne, Lincolnshire PE10 9PH

Bibliographic codes ISSN 0953-8585 (print)  
ISSN 2058-7058 (online) CODEN PHW0EW

## EU RP (for authorities only)

eucomply OÜ Pärnu mnt 139b-14, 11317 Tallinn, Estonia  
[hello@eucompliancepartner.com](mailto:hello@eucompliancepartner.com) +33757690241

## Contact us

Got feedback, a letter to the editor or an idea for an article? We'd love to hear from you.

## Physics World

No.2 The Distillery, Glassfields, Avon Street, Bristol BS2 0GR, UK

Tel +44 (0)117 929 7481

E-mail [pwld@iopublishing.org](mailto:pwld@iopublishing.org)

Web [physicsworld.com](http://physicsworld.com)

LinkedIn [physics-world](https://www.linkedin.com/company/physics-world)

Bluesky [physicsworld](https://bsky.app/profile/physicsworld)

## Institute of Physics

37 Caledonian Road, London N1 9BU, UK

Tel +44 (0)20 7470 4800

E-mail [membership@iop.org](mailto:membership@iop.org)

Web [www.iop.org](http://www.iop.org)

The contents of this magazine, including the views expressed on this page, are the responsibility of the editors. They do not represent the views or policies of the Institute of Physics, except where explicitly stated.

Copyright © 2026 by IOP Publishing Ltd and individual contributors. All rights reserved.

## physicsworld

Explore [physicsworld.com](http://physicsworld.com)

## NEWS

Discover the breaking stories affecting the global physics community, from funding and facilities to people and policy.

[Click to read](#) →

## RESEARCH UPDATES

Keep up to date with the most significant new physics research breakthroughs, from astrophysics to the Z boson.

[Click to explore](#) →



Photo: NASA/Frank Michaux

## physicsworld | STORIES

Reflecting on NASA's Artemis II mission, Ambre Trujillo of the Planetary Society discusses the excitement surrounding humanity's return to lunar exploration. The episode also examines the environmental impact of spaceflight with Alexis Normand, whose company, Greenly, specializes in carbon accounting.

# Quantum Computing Microwave Components/System Integration

## ➤ Cryogenic Components



Cryogenic Low Noise Amplifier    Cryogenic Bias Tee    Cryogenic Isolator / Circulator



Cryogenic Low Pass Filter    Infrared filters    Cryogenic Attenuator

## ➤ Interconnect solutions



Low Loss & Phase Stable Cable Assembly    Hermetically sealed Adapters    Cryogenic Coax & Superconducting Cable



Cryogenic Bulkhead Connector Mounting Plate    Twisted Pair Wiring    Non-Magnetic Cryogenic Bulkhead Adapter

## ➤ Microwave Components

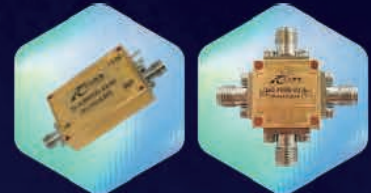

Low Noise Amplifier    IQ Mixers

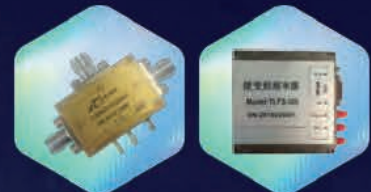

High-speed RF Coax switch    InfraUltra-Low Phase Noise Frequency synthesizer

## ➤ High-Density Wiring

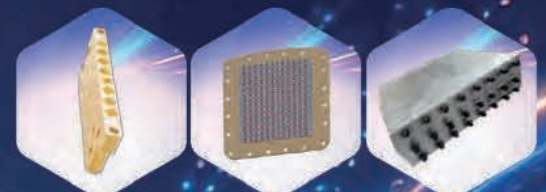

High-density Cryogenic Filter, Infrared Filter, attenuators    High density thermalized bulkhead Adapter    Multi-channel Frequency synthesizer



Cryogenic Silver-Epoxy Filters    High-density Hermetic Feedthrough    Multi-port cable assembly



## Setting the course for physics

New IOP president **Paul Howarth** tells Michael Banks that communicating the relevance of physics to society has never been more important

With a PhD in nuclear physics, Paul Howarth has had a long career in the nuclear sector, working on the European Fusion Programme and at British Nuclear Fuels, as well as co-founding the Dalton Nuclear Institute at the University of Manchester. He was a non-executive board director of the National Physical Laboratory and served as chief executive officer of the National Nuclear Laboratory.

Howarth became president-elect of the Institute of Physics (IOP) in September 2025. In February he became IOP president after space physicist Michele Dougherty stepped aside from the role to avoid any conflicts of interest given her position as executive chair of the Science and Technology Facilities Council. Howarth is set to be IOP president until 2029. *Physics World* recently caught up with Howarth to find out more about his career and vision for physics.

### What originally sparked your interest in physics?

I think it probably came from my father. He was a research chemist. We lived in Cheshire near the Jodrell Bank Observatory and its iconic Lovell Telescope. I was fascinated by that and it captivated my interest in astronomy and so I did a degree in physics and astrophysics at the University of Birmingham.

### You stayed at Birmingham to do a PhD in nuclear fusion. What attracted you to that field?

It goes back to my interest in astronomy and the ability to use mathematics to describe the universe. Yet by the end of the degree, I was fascinated by nuclear fusion as an energy source and a sustainable means of clean energy for society. During my PhD, I got to work on the JET tokamak in Oxfordshire, which was wonderful. It was when JET was doing its first deuterium-tritium plasma shot, which was an exciting time.



Institute of Physics

**Forward planning**  
Nuclear physicist Paul Howarth became president of the Institute of Physics in February 2026 and will stay in the role until 2029.



Listen to an extended version of this interview

### After your PhD, you worked for British Nuclear Fuels. Why did you make that move and what appealed about the commercial side of physics?

In the 1990s there was quite a bit of uncertainty about the direction of nuclear fusion, but I'd always been fascinated by the huge monolith structures of nuclear power stations. So I didn't hesitate when an opportunity arose to work at Sellafield – a huge site in north-west England with more than 200 nuclear facilities – on understanding the physics of plutonium.

### You then served as chief executive officer of the UK's National Nuclear Laboratory. How did that come about?

At British Nuclear Fuels I was working to build the case for the next generation of nuclear power plants. But in the early 2000s it was less clear that nuclear was going to be part of the UK's energy policy. So British

Nuclear Fuels was broken up into organizations such as the Nuclear Decommissioning Authority. But I was determined to continue to make the case for new nuclear build and ended up helping the UK government create a National Nuclear Laboratory to maintain sovereign nuclear capability, becoming chief executive officer in 2011.

### What did that role involve?

We had contracts to support all aspects of the UK's nuclear programme as well as build the case for future nuclear. We worked on the front end of the fuel cycle, on reactor technology, on future reactors, on legacy waste management and decommissioning. I had the responsibility for running about £2–3bn of critical nuclear real estate and infrastructure.

### Many countries, not just the UK, are showing a renewed enthusiasm for nuclear – what do you attribute that to?

Yes, it's a fascinating time for nuclear. I think things are heading now towards small modular reactors and advanced reactor systems. Larger nuclear plants are more efficient but it is possible to trade that off for smaller plants. This opens up the opportunity for others to potentially invest in nuclear. So we see, for example, individuals like Bill Gates and others who are looking at nuclear power.

### Do you see parallels with the fusion industry and how that has grown in the past decade?

Absolutely. I think a very similar thing has happened. Of course, there's still the engineering challenges associated with scaling up fusion but good progress is being made. And other players and entities, like Tokamak Energy and First Light Fusion, are looking at entering the market, which is great.

## Having retired from the NNL in 2025, what drew you to the role of IOP president?

It was the opportunity to give something back to physics. Physics is such an important discipline that is needed across all aspects of society and through my time working in physics, I've seen the benefits that it brings.

## What things excite you as you take up this position?

When we look across society, the impact that physics is having is massive – whether that is in data centres, artificial intelligence, net zero, medicine or even food supplies. One of the things I would like to achieve during my presidency is to qualify and quantify that impact. The role that physics can play is going to be fascinating and to be part of that journey is exciting.

## What are your priorities as president?

One is to nudge the dial on getting physics recognized in society as a really valuable and important discipline. This includes making sure that schools are properly equipped and resourced for teaching physics as well as having more teachers with a physics background. This would then hopefully translate into more people studying the subject at A-level and degree level.

## UK Research and Innovation (UKRI) recently announced funding changes that will see cuts to particle and nuclear physics. How do you see that impacting physics?

Yes, it's a challenging time at the moment. We've been working hard to ensure that the impact is properly assessed and that we are doing what we can to champion and support some of these critical disciplines in physics. I can understand the direction of travel from UKRI, which is the importance that the investment underpins and supports economic growth. And there are some key critical disciplines such as quantum computing, autonomous system robotics and fusion that continue to be supported and where funding has actually increased. But what we are concerned about is the potential adverse or detrimental effects of a reprioritization that may move fund-

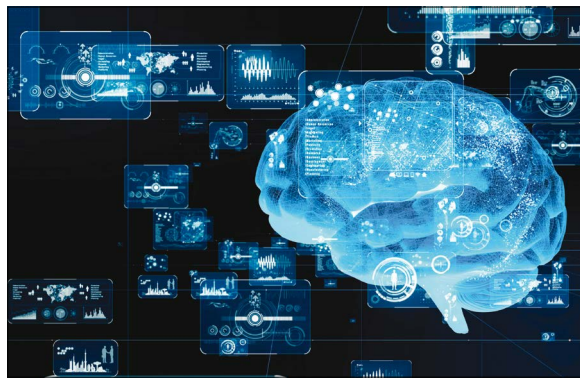

istock/metamorworks

ing away from some critical areas in physics, such as particle physics, astronomy and nuclear physics. That is a concern because they are fundamentally important disciplines.

## Could there be an impact on people wanting to go into these areas?

What I worry about is the negative impact on university physics departments that work in those areas. It's also those areas of physics that really captivate people to study the subject. But there is a knock-on effect on other areas too because many people who study physics go into engineering, which is crucial for other industry sectors – whether it's around detectors, data systems, data acquisition, electronics, power systems, automotive, aerospace, defence or nuclear energy. So I worry that the reprioritization is not properly assessing the impact and the benefit the subjects have.

## How is the IOP tackling this issue?

We need to ensure that we fight the case for those areas of physics, because they are so important. We need to find a path that ensures we maintain these critical areas but also ensure that investment is being made to support economic growth as a whole.

## How do you strike that balance between being vocal about the cuts, but also needing to support emerging areas of physics?

I think that's the challenge – to effectively support all aspects of physics. I don't want to be in a position where we are pitching one area against another. It's the totality of the capability, and that's all aspects of physics and the interrelationship between those disciplines too. We should celebrate where there is growth in new

**Machine learning**  
The IOP's *Physics and AI Impact Pathfinder* report highlighted the role of physics as both enabler and beneficiary of AI.

and exciting areas. But equally, we must protect those areas that are fundamental pillars of physics

## Are there any opportunities even in this difficult situation?

As we continue to engage government and other stakeholders on these funding changes, there is an opportunity to define physics' impact as a benefit to society as well as big opportunities for science-driven growth arising from increased investment in key areas. I believe that a developed nation like the UK, which has a very good international standing, should continue to invest in all aspects of the discipline.

## What other challenges lie ahead?

It is really important that we remain an inclusive discipline and we also need to get our heads around the impact of AI on physics. The IOP has already done some work with the community in this area with the *Physics and AI Impact Pathfinder* report, which highlighted the role of physics as both enabler and beneficiary of AI, and also explored the discipline-specific views physicists hold regarding AI in science and society. I am interested in us understanding more about what AI means for physics and being a physicist, how we embed AI in the training of physicists so physicists can use it and become better physicists. I would be keen for the IOP to carry out more work to understand the impact it's clearly going to have.

## How do you see the subject evolving over the coming decade?

I think that society is embracing what science and technology, and in particular physics, can do. We need to help ensure that the next generation of physicists are being appropriately trained to become good physicists. In fundamental physics, there are some fascinating things developing like bringing together cosmology and quantum physics, understanding quantum gravity, the nature of time and what's happening down at the particle physics level. It feels as if something's coming together. I'd love to be around when physics can finally pull all of that together and go "we've got it – the light bulb's gone on".

**Michael Banks** is news editor of *Physics World*

## Exam board fined for ‘serious errors’

The exam board Cambridge OCR has been hit with a fine of £270 000 for errors in A- and AS-level physics exam papers, as **Michael Banks** reports

The UK exam board Cambridge OCR has been fined £270 000 for “serious errors” relating to A- and AS-level physics exam papers in 2025, which meant some students were issued with the wrong grades. The fines – issued by the Office of Qualifications and Examinations Regulation (Ofqual) – have been welcomed by teachers and the Institute of Physics (IOP).

A levels are mostly taken by 18 year olds in England, Wales and Northern Ireland, with the grades being used by universities to decide admission. Between April and October 2025, a total of 12 errors were identified in Cambridge OCR’s AS- and A-level physics exam papers and mark schemes that guide examiners.

About 14 000 students sat the OCR exam papers 1 and 2 in 2025. Some of the errors were identified before exams, and correction notices were issued to schools to correct the mistakes. But others were identified after the exams had taken place and this led to some cases where incorrect grades were issued. The errors involved wrong data in a table as well as data not matching graphs.

Ofqual’s investigation found that the incidents were caused by “inadequate systems of control, workplace competence and insufficient workplace capacity”.

“Students deserve quality exam assessment materials. After years of hard study, these unacceptable failures caused anxiety for students during their exams. Some were issued incorrect grades,” says Amanda Swann, executive director for delivery at Ofqual. “We will always act to protect students’ interests and maintain public confidence in our qualifications system.”

Rachael Houchin, head of physics at Royal Grammar School Newcastle, says she is “pleased” by the action taken by Ofqual. “Mistakes in high



**Under examination** Cambridge OCR has been fined £270 000 for errors in physics exam papers.

stakes assessments have real consequences for students, and a fine of this scale rightly recognizes that,” Houchin told *Physics World*. “However, it does not repair the damage done to the confidence that schools, pupils and parents place in their qualifications, and OCR will need to demonstrate that its processes have been strengthened to rebuild that trust.”

### Steps taken

In issuing the fine, Ofqual took into consideration that Cambridge OCR accepted the breaches and had taken action to minimize the impact on students, standards and public confidence. The exam board also provided an “action plan” to prevent the errors recurring in future exams.

In a statement, Cambridge OCR apologised for the error, adding that it “did not meet the high standards that students and teachers deserve”. “We are determined to learn from this and to improve, and we are continually refining our processes,” says Myles McGinley, managing director of Cambridge OCR. “We’re grateful to all the physics teachers, students, subject experts and Ofqual for their scrutiny, feedback and insights that have helped improve our approach.”

OCR was not alone in facing criticism for errors in 2025 A-level physics exam papers. Physics paper 2 from the rival AQA exam board was also seen to contain complex phrasing that hindered students’ ability to answer the question and led to time pressures.

A small survey of physics teachers carried out after the exams by the IOP found that 41% were dissatisfied with the OCR physics exam papers, while two-thirds of teachers reported that students had a negative experience during the AQA exam.

Tom Grinyer, chief executive of the IOP, welcomes the steps taken to address the errors. “We have worked closely with Ofqual and Cambridge OCR since raising serious concerns at the time about the impact on students, their families and physics itself, to ensure this does not happen again,” says Grinyer. “Cambridge OCR’s commitments and the action taken today by Ofqual should provide important reassurance to students, teachers and universities and help ensure that confidence in physics qualifications is maintained, allowing physics to continue to grow in popularity at a time when physics skills are so in demand across our economy.”

Despite the issues, almost 45 000 students took A-level physics in the UK in 2025 – a rise of 4.3% on 2024 – to reach the highest level for 25 years. Physics is now the sixth most popular subject at A level, up from ninth last year, with girls representing a quarter of all candidates. “It’s incredibly important Cambridge OCR has committed to concrete actions to avoid these issues repeating in the future, which could otherwise jeopardize this growing popularity,” adds Grinyer.

**Michael Banks** is news editor of *Physics World*

A HAMAMATSU COMPANY

# Lasers for Quantum Technologies

Do you want to design your own laser system? You can! Mix and match our modular building blocks to create the laser system you need for your quantum experiments. Pick your wavelength and power. The low noise, narrow linewidth, and industrial reliability are standard.

Contact us to learn how our fiber laser modules can advance your quantum sensing, computing, or metrology projects.



Contact us!  
[nktphotonics.com/contact](https://nktphotonics.com/contact)

**NKT**  Photonics

# Why patents are so vital for the quantum economy

Physicist and patent attorney **Mark Saunders** explains why intellectual property is crucial if we are to build a vibrant commercial quantum industry



The quantum revolution is no longer a distant dream. It is unfolding right now, promising to shake up computing, communication and security on a global scale. The race to harness these transformative technologies will not, however, be determined by who succeeds in manipulating qubits – but by who can secure the ideas that make this technology possible.

Intellectual property (IP) is the currency of innovation, and in the quantum era, it will determine whether breakthroughs become valuable assets or lost opportunities. Quantum physics has already made a huge contribution to global economic growth: just think of the billions of transistors in the smartphones that we carry around in our pockets.

But the “quantum 2.0” revolution, which will exploit phenomena such as superposition and entanglement, is set to bring us entirely new kinds of devices. In fact, quantum computers are already developing so fast that they will soon complement (even if they probably won’t entirely replace) the classical computers we all take for granted.

Given the huge potential, it’s hardly surprising that

many countries around the world have national quantum research programmes. The UK, for example, recently announced unprecedented levels of grant funding in this area as it enters a second – and hugely ambitious – 10-year quantum initiative. Bringing together entrepreneurs and inventors from diverse fields to develop scalable qubit architectures and quantum-secure networks, the programme is well placed to deliver a strong return on the initial investment.

Another sign of the UK government’s commitment to quantum technology, despite well-publicized cuts to other areas of physics research funding, is the SpeQtre satellite. Launched late last year as a collaboration between the Science and Technology Facilities Council, RAL Space

### Value added

A successful quantum-technology sector will depend on firms taking out the right kind of intellectual property.

**IP assets are important, being essentially government-awarded prizes that encourage innovation**



**Missed opportunities** The UK has too often led the way in basic quantum physics but then failed to benefit economically from applications in areas like ultra-secure communication, which is why IP assets are so vital.

and Singapore's SpeQtral, it will test how "encryption keys", based on entangled particles, could lead to ultra-secure space-based communication.

For too long, though, the UK has pioneered groundbreaking achievements, but failed to turn those accomplishments into economic benefits. That's why IP assets are so important, being essentially government-awarded prizes that encourage innovation.

When it comes to patenting quantum technologies, however, companies in the UK and the rest of Europe are falling behind competitors in the US and China. There is still time to catch up. But we risk losing out – even in our own markets – if UK businesses fail to protect their quantum innovations.

### Patent protection

Despite being so counter-intuitive, quantum technologies need to satisfy the same patentability requirements as any other type of invention. They must, in other words, be new, inventive, industrially applicable, not excluded from patent protection, clearly defined and sufficiently explained.

Patent laws around the world are these days largely harmonized, although there is some divergence in how different countries assess whether an invention should be excluded from patentability. In the UK and Europe, for example, there are ways to get around patent exclusions for innovation that relates to discoveries, scientific theories, mathematical methods, business methods and computer programs.

Patent law is continually developing as it catches up with emerging science, especially in areas such as quantum computing, artificial intelligence (AI) and smart technology. The UK Supreme Court, for example, recently handed down a judgement that brought UK law up-to-date regarding how the patentability of inventions is assessed, especially those related to AI software.

When it comes to assessing patentability, quantum

## Building a robust IP portfolio is paramount for persuading investors that they should take the opportunity to support the deployment of quantum solutions

computing is held to the very same standards as classical computing. Quantum algorithms, for example, can be patented by demonstrating technical effects that have been achieved. What's more, guidance provided by the UK Intellectual Property Office explains that aspects of superconducting and/or photonic circuits for controlling processing and measuring qubits would likely escape exclusion.

Developments in quantum theory can be protected too, although to obtain patent protection, the patent application will need to explain how those quantum effects could be implemented by bringing together hardware that is already available today. It is worthwhile as well for patent applications that cover quantum innovation to set out the commercial opportunities that are envisaged.

### Audit your assets

But it's not all about patents. If you are looking to launch a business in the quantum sector, there are some other IP rights that are worth bearing in mind too. Registered designs, for example, can protect the appearance of products that you have created. Semiconductor topography rights can protect the design of integrated circuits, while trade marks can protect your brand, so that your business stands out from the rest of the market.

An IP audit by a patent attorney will help to identify the variety of ways to commercialize your quantum innovation, while also highlighting the risks as well as the potential opportunities too. Building a robust IP portfolio is paramount for persuading investors that they should take the opportunity to support the deployment of quantum solutions.

Remember though, that if you intend to pursue patent protection, you'll need to file your patent application before your innovation is revealed to anyone who is not obliged to keep it confidential. Before you publish quantum physics research, you should therefore seek advice from a patent attorney, to ensure that your IP strategy aligns with your commercial objectives.

As theoretical and experimental quantum science matures into commercial applications and government industrial strategies, physicists will continue to make a vital contribution in shaping how their discoveries are to benefit our society. Together we will build a successful quantum economy.

With a background in quantum physics, **Mark Saunders** is a UK and European patent attorney at ip21 based in London, UK

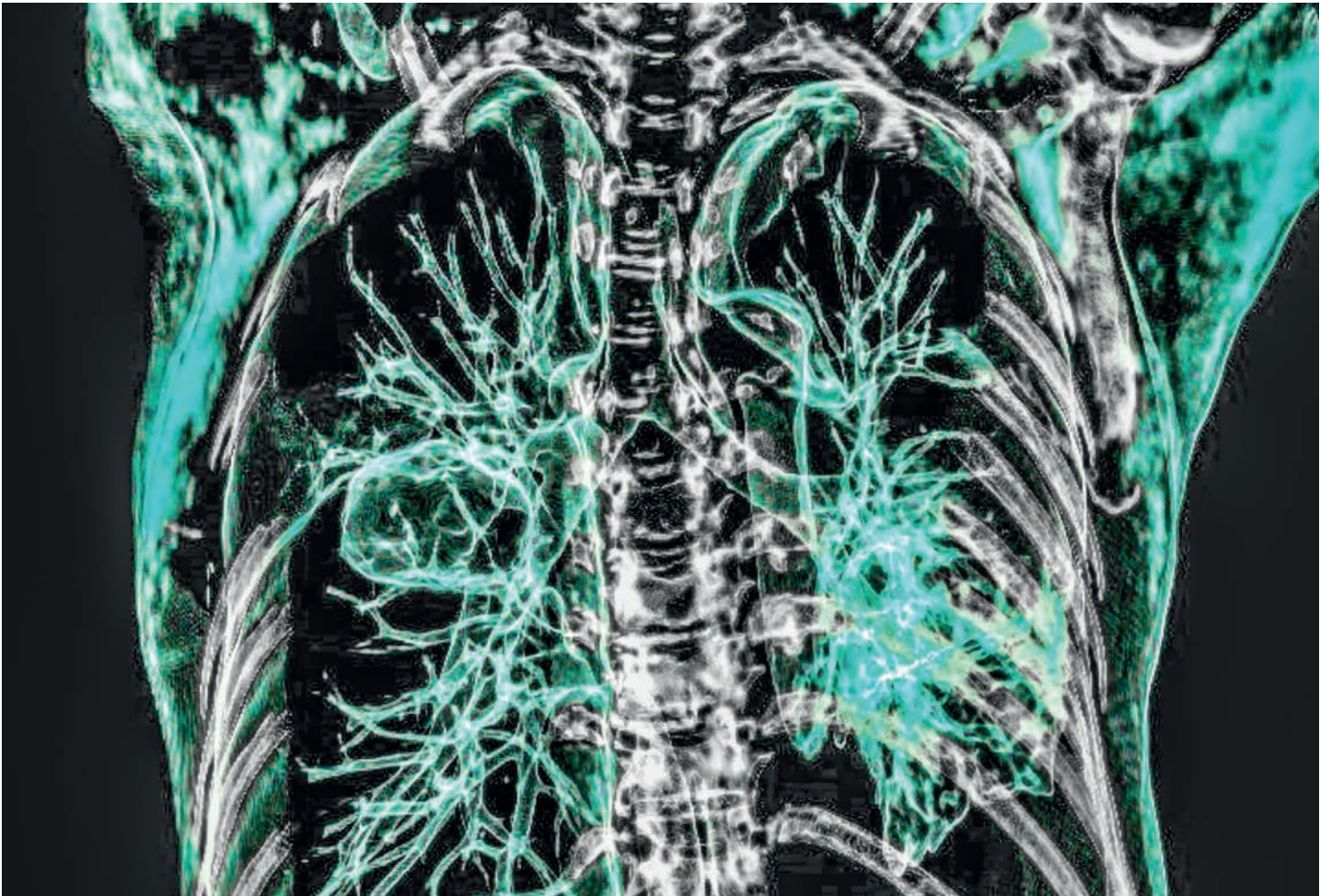

**physicsworld** L I ▼ • E

in partnership with *Reports on Progress in Physics*<sup>™</sup>

# MEDICAL ▲ PHYSICS

**Wednesday 1 July 2026, 2:00 p.m. BST**

*Physics in Medicine & Biology* (PMB) celebrates 70 years.  
Join us as we reflect on contributions to medicine and biology.

## **Confirmed speakers**

**Katia Parodi**, Ludwig-Maximilians University Munich, Germany

**Simon Cherry**, University of California Davis, US, and King's College London, UK

**Steve Webb**, Institute of Cancer Research and the Royal Marsden Hospital, UK



**Register today**

# THERE IS ALWAYS LIGHT



## Ampheia.

- Ultra-low noise single frequency fiber laser systems
- 1064 nm & 532 nm, up to 50 W
- Perfect for optical trapping, holography and laser pumping



**HÜBNER Photonics**  
hubner-photonics.com



# Quantum through pictures

**Muhammad Sabieh Anwar** explains how the summer school Quantum in Pictures helped school students understand quantum physics without the maths

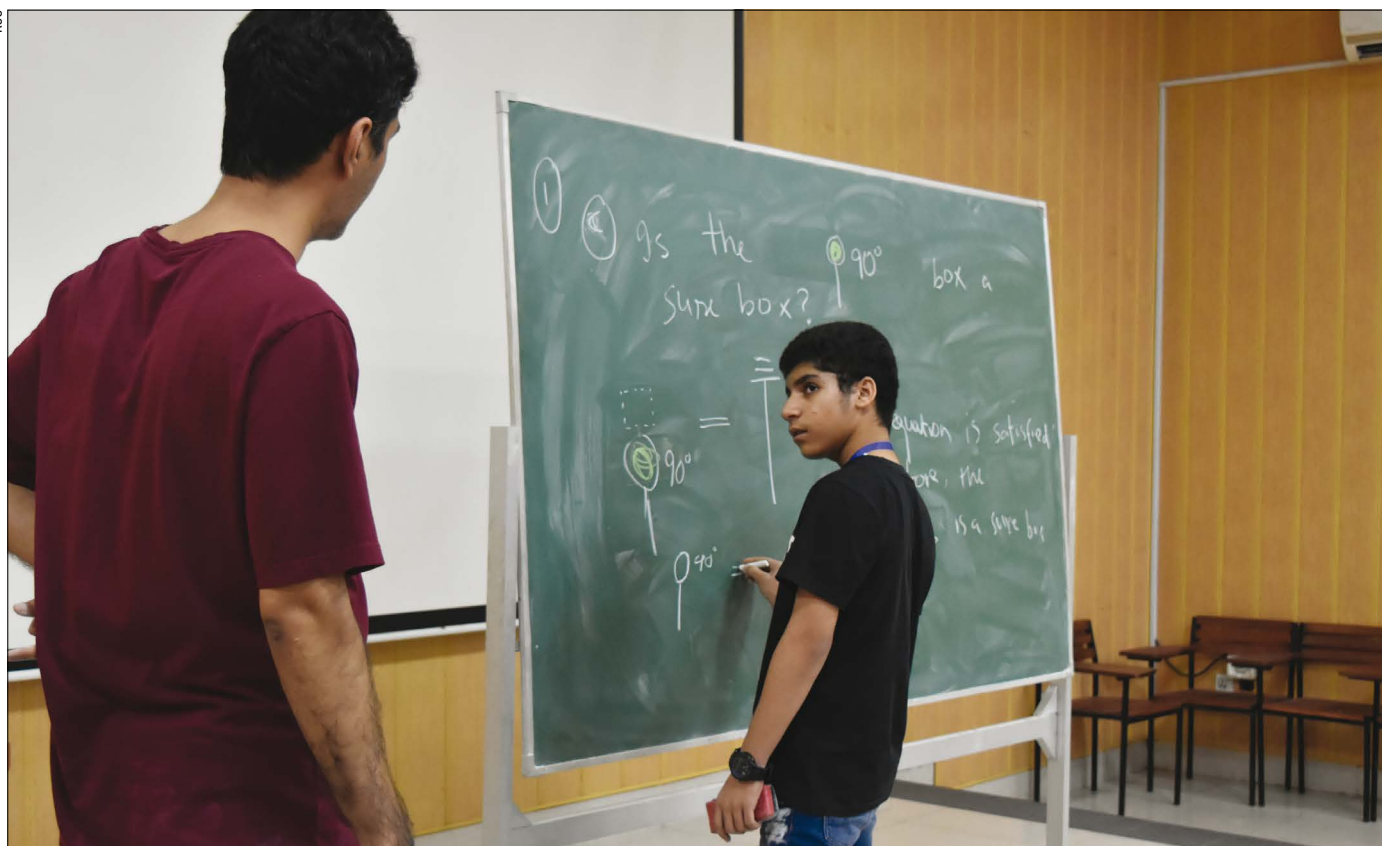

Humans perceive knowledge, make decisions and build the consciousness of knowing through vision and speech. This interplay between visual and nonvisual patterns collectively shapes how we learn complex concepts such as quantum physics. That is despite the subject's reputation as being incomprehensible and difficult to reconcile with our everyday conceptions.

The issue when teaching quantum mechanics also lies in the shortcoming of using literary constructs to accurately describe what quantum mechanics really means. As the Hungarian-British philosopher Michael Polanyi once noted: "We always *know* more than we can *tell*." It is hard to accurately capture in language the full meaning of quantum phenomena such as nonlocality, superposition, no-cloning, teleportation, counterfactual quantum computation, delayed choice or the many other uniquely quantum phenomena.

This also means that terms such as wave, particle, superposition and entanglement are not truly complete until followed by detailed calculations or elaboration of their consequences. The result is that introductory quantum mechanics courses often require prerequisite

mathematical grounding in complex numbers, matrices, linear algebra and differential equations.

Yet I believe this tortuous preparation can be bypassed – in an accurate, comprehensive and consistent way – simply through "pictures". With that in mind, we conducted an experiment last year at Government College University in Lahore, Pakistan – alma mater of the physics Nobel laureate Abdus Salam. The four-week-long summer school – Quantum in Pictures – was organized by the Khwarizmi Science Society, a not-for-profit grassroots science association that aims to make scientific education accessible especially for resource-deprived communities.

Some 50 school students attended lectures and demonstrations led by Muhammad Hamza Waseem from the UK firm Quantinuum, who works with Bob Coecke, one of the founders of a pictorial approach towards quantum physics and education.

Most of the students, who had no prior knowledge of quantum mechanics, came from Lahore while the remainder were from nearby towns and villages where opportunities especially in advanced fields are generally minimal. On top of that classroom engagement is largely

### Visual learning

The Quantum in Pictures course involved using string diagrams to capture ideas about how quantum states transform.



discouraged and an outdated model of examination fosters rote learning. Almost half of the participants who attended the school were girls, with 75% of participants aged between 14 and 18 – the youngest being a 13-year-old girl from a village called Syedanwala in Kasur.

To capture ideas about quantum mechanics, we used “string diagrams” as our basis. Such diagrams, simply put, are made using boxes that represent processes. Wires coming in at the top and at the bottom represent the input and output systems being processed by the box. Simulating quantum processes translates to connecting boxes with wires, chopping and straightening wires or sliding boxes along wires like beads on a string.

Even though this formalism is rigorous and derived from category theory, the manner in which it is presented is unhindered by burdensome abstractions. In terms of quantum mechanics, such diagrams are able to capture ideas about how quantum states transform, how quantum operations work as well as counterintuitive notions about measurement.

### A new confidence

When I teach quantum mechanics to undergraduates, colleagues often discourage me from “spilling the beans” on quantum mechanics too early before we have covered the mathematical acrobatics of Hilbert spaces, unitary transforms, eigenvalues and Dirac’s bra-ket notation. Yet I believe school students should relish the counterintuitive repercussions of quantum mechanics much earlier than they currently do. I believe that introducing such aesthetic visuals – an overlooked concept for learning – can make the discipline more comprehensible and attrac-

tive to students.

A diagrammatic technique helps to avoid all this and democratizes the knowledge of our quantum world. After all, the future quantum workforce must be trained earlier than ever, given we do not want students missing out on the quantum revolution. In addition, quantum computing is not the purview of physicists alone. Many computer scientists and programmers, who will never be formally trained in physics, will need an initiation in quantum mechanics.

When it comes to making education accessible and within the direct grasp of millions of eager learners, demystifying traditional modes of learning and introducing new approaches helps students and teachers. Learners gain the confidence to ask questions, synthesize connections between bodies of knowledge and prepare themselves for a workforce that may require competency instead of a paper degree.

According to a survey of students who completed the course, 60% engaged in interactive discussions or used the chalkboard to solve problems while 80% asked or responded to questions. For most of these students, this level of engagement with the instructor was a first in their lives. This is the confidence that our liberated students walked away with as they completed their final exams in the Quantum in Pictures summer school.



**Muhammad Sabieh Anwar** is a physicist at the Syed Babar Ali School of Science and Engineering, LUMS. He is founder of the Lahore Science Mela, Pakistan’s biggest citizen science fair, and is general secretary of the Khwarizmi Science Society

### Getting together

Some 50 school students, almost half of whom were girls, gathered last year for the four-week-long summer school Quantum in Pictures.



Think Nano®  
Positioning | Microscopy | Solutions

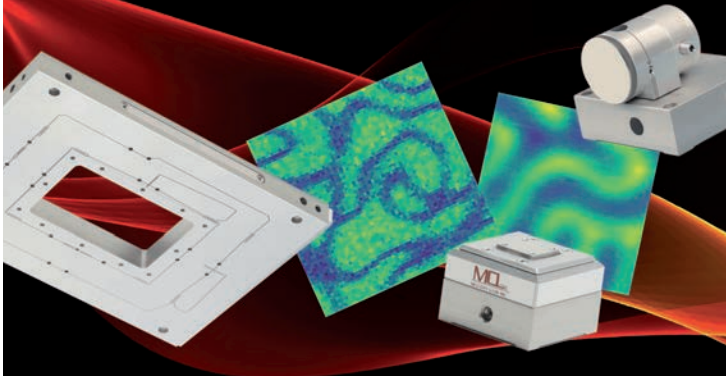

Closed Loop Nanopositioning  
Micropositioning  
Atomic Force Microscopes  
DIY Quantum Scanning Microscopes  
Custom Solutions

sales@madcitylabs.com • www.madcitylabs.com



Applied Quantum Computing bridges cutting edge quantum algorithm research and real world application. In collaboration with end user partners, we research and develop quantum computing software applications of high commercial and societal importance, with a focus on quantum optimisation and quantum machine learning. We have particular expertise in the healthcare and financial services sectors and are members of the IBM Quantum Network.

Backed by a recent round of external fund raising, we are looking to expand our research team with select hiring.

We are particularly interested in:

- PhD students and graduates specialising in quantum algorithms
- Computer scientists with a strong interest in quantum computation

You need to be enthusiastic about the potential of quantum computing and the opportunity to work for a start-up whose mission is to bring this exciting technology to the user in accessible form.

If this could be you, get in touch by sending your CV and a covering letter to [recruitment@aqcquantum.com](mailto:recruitment@aqcquantum.com)

[www.aqcquantum.com](http://www.aqcquantum.com)



# ALUMINUM + TITANIUM CHAMBERS

*Better Vacuum*

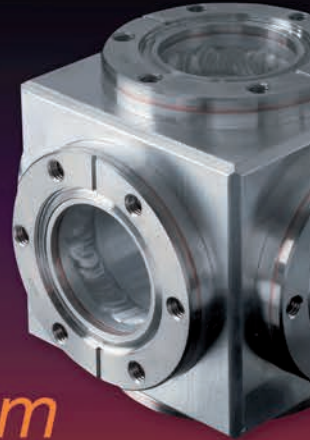

# SPECIALTY BIMETAL COMPONENTS

*Optimized  
Performance*

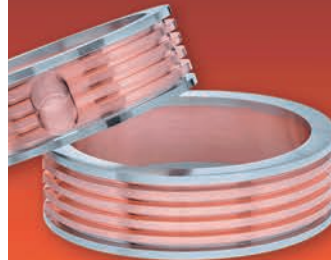

[AtlasUHV.com](http://AtlasUHV.com)



# Fiber Optic Components for Quantum and AI Systems



FM 63463 Canada FM 577647 China FM 601414 Turkey



**Fiber Based Polarization Entangled Photon Source**

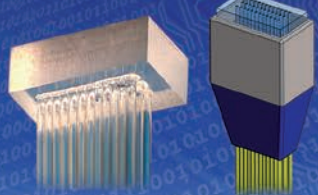

**2D Fiber Matrix Array (2D FMA) Assemblies**



**12 & 16 channel MPO/MTP<sup>®</sup> Polarization Maintaining Fiber Assemblies**



**Polarization ER Meters for MPO/MTP<sup>®</sup> Connectors**



## OZ Optics

[shop.ozoptics.com](http://shop.ozoptics.com)  
[www.ozoptics.com](http://www.ozoptics.com)



219 Westbrook Road, Ottawa, Ontario, K0A 1L0, Canada | Toll free: 1-800-361-5415  
Tel.: 1-613-831-0981 | Fax: 1-613-836-5089 | E-mail: [sales@ozoptics.com](mailto:sales@ozoptics.com)

**Fiber Optic Products at Low Cost. Ask OZ How!**

## PAPS 2026

**9-11 September 2026, 8am-6:30pm**  
University of Nottingham, Nottingham, UK

The 32nd biennial meeting of the Polymer Physics Group, PAPS 2026, will be held in Nottingham in September 2026. This event provides an opportunity for researchers from both academia and industry to discuss the latest innovations in understanding and manipulating the physical behaviour of a wide range of polymeric systems. PAPS 2026 will aim to highlight the role that polymer physics plays in topical areas such as sustainable energy and materials, medicine and health, as well as how machine learning is advancing our understanding of polymer systems.

In addition to invited talks from world-class experts, the conference will feature the 2026 Founders' prize lecture and a presentation from the DPOLY Exchange Lecturer. Contributed presentations are welcomed from postgraduate students and established researchers alike, across a broad range of polymer physics topics.

**We invite you to register online by 31 July 2026, in order to take advantage of the early registration deadline.**

**Key Dates:**

Submission Deadline: **30 June 2026**

Early Registration Deadline: **31 July 2026**

Registration Deadline: **28 August 2026**



For more information, visit the website at [iop.eventsair.com/paps2026](http://iop.eventsair.com/paps2026) or email [fatima.kanu@iop.org](mailto:fatima.kanu@iop.org)

**IOP** Institute of Physics

# The strange metaphor of Euglena's tail

A single-celled organism provides an excellent metaphor for what quantum mechanics says about the world.

**Robert P Crease** and **Gino Elio** explain

Quantum mechanics is so full of strange phenomena that it's not surprising that physicists have had to dream up some vivid metaphors to explain them. Who can't help but think of cats in boxes when contemplating superposition or balls of jumbled yarn when musing over entanglement? Like all metaphors, these use familiar experiences to help understand the unfamiliar.

Metaphors come in many different types. "Love is a rose", for instance, is a "filtrative" metaphor, in which a secondary subject (a rose) guides us how to perceive another, primary subject (love) by drawing our attention to key features.

In a "creative" metaphor, however, the secondary subject eventually becomes the technically correct term for the primary subject. This has happened over and over again in quantum mechanics: entanglement, superposition and spin are all examples.

A third kind is a "perceptual" metaphor, which seeks to recast our overall view of something. A good example is physician Lewis Thomas's remark that the Earth is "most like a single cell".

But one extraordinary metaphor proposed 10 years ago by Christopher Fuchs, a physicist at the University of Massachusetts Boston, involves a type of algae known as Euglena. Fuchs decided to invoke this single-celled, biological organism to help understand not just one quantum-mechanical phenomenon but possibly the deepest mystery of all: the relationship between quantum formalism and the world around us.

### Subjective matters

Ever since Werner Heisenberg and others developed quantum mechanics more than a century ago, physicists have been debating what it means and what it says about the world. Over the years, there have been many different points of view, or "interpretations", of quantum mechanics, but they all fall into two main camps.

One set claims that the formalism of quantum

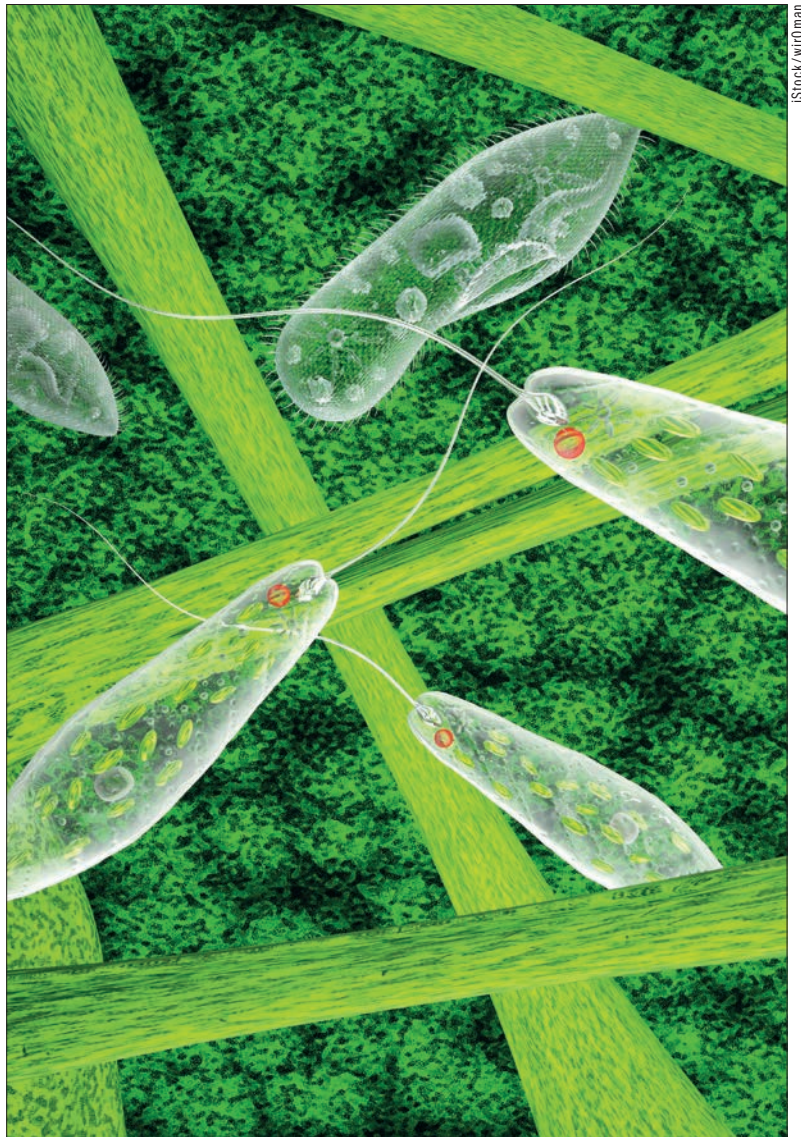

**Strange parallel** Proponents of an interpretation of quantum mechanics known as "QBism" have devised a metaphor involving Euglena – a single-celled freshwater algae that has a long whip, or "flagellum", that can sense nutrients and propel it towards the food.

mechanics quantifies some actual, objective structure that existed even before humans and is independent of what we do. Another set of interpretations treats the formalism like a tool that lets humans make predictions about the world. In philosophical terms, the former interpretations are "ontological" and the latter "epistemological".

**QBism states that any measurement we make – whether determining the spin of an electron or stamping our feet on the ground – is a new creation**

Fuchs and a loose conglomerate of physicists and philosophers, however, have been advocating an entirely different approach, known as QBism. It says that any measurement we make – whether determining the spin of an electron or stamping our feet on the ground – is a new creation; it’s an experience that never existed in the world before. Quantum states aren’t therefore real states of affairs in nature but subjective probabilities we assign to our interactions with the world.

Subjective probabilities aren’t as strange as they sound, simply describing a user’s degree of belief about an individual event. Objective interpretations, in contrast, see probability distributions as physical. QBism’s conclusion that many pieces of the formalism are subjective simultaneously distances our subjective control over nature. For a one-horse race, I can predict the winner with certainty, but nevertheless, the race can still get washed out by rain. Even if I make a prediction with certainty about an event, nature can throw us a curveball and do otherwise.

For Fuchs and his supporters, quantum theory is therefore an appendix to Bayesian probability theory. Originally developed by the British philosopher and statistician Thomas Bayes in the 18th century, it evaluates a user’s judgment about how likely an outcome is (such as whether a horse will win a race) rather than being about pre-existing states of affairs (such as passively recording the speed of particles in a gas).

Fuchs calls his interpretation of quantum mechanics QBism as it derives from the term “Quantum Bayesianism”. Quantum mechanics, according to Fuchs, is a “user’s manual” that “anyone can pick up”, devised by experienced players to guide individual experimentalists to make wise bets on measurement outcomes.

The key point is that while quantum state assignments are subjective, the rules underlying them aren’t. They have been analysed, evaluated and corrected over time by communities of physicists. Subjective interpretations of quantum mechanics treat the formalism as something for individuals to use and apply for all kinds of physical phenomena.

### Enter Euglena

If you’re struggling to get your head around all of this, that’s where Euglena comes in. It’s a single-celled freshwater algae, roughly 50 microns long, that has a long whip or “flagellum” that can sense nutrients and propel the organism towards the food. The tail, which is the product of many years of evolution, helps only the organism to which it is attached. However, by studying it, we can learn not just about an individual Euglena but also the wider environment in which it moves.

The metaphor of Euglena’s tail therefore does two things. First, it expresses the idea that quantum formalism is a manual – a means to get around in the world. Second, it says something about how we interact with the world.

Each organism uses its inherited tail, constantly tested and improved by a community of others, to “guess” how to get around in its environment. But each time the organism does, it encounters something in the environment it never did before.

## Quantum physicists, too, cannot become “outsiders”. They have no external standpoint from which to look down on the world

Euglena’s tail can, in other words, help us to explain why quantum mechanics can be both a single-user theory and the product of extensive study. “By dissecting it,” Fuchs wrote in a 2016 arxiv preprint (1601.04360), “you can learn something about the world that all of us are immersed in.”

Like all metaphors, however, Euglena has its shortcomings.

Imagine standing above the Euglena and observing it through a microscope. It would be perfectly reasonable to say that “there is” an environment that the organism senses “thanks to” the whip. We might also conclude that what a Euglena encounters is objective, independent of its presence, and could be predicted by the organism, provided it had enough data and processing ability.

But all this assumes we are looking down from above to adopt a point of view completely detached from Euglena and its environment; we, as researchers, are outsiders. The Euglena organism itself is different. It has no such outside standpoint and each move is creative, encountering a fresh environment.

Now here’s the key point of the metaphor. Quantum physicists, too, cannot become “outsiders”. They have no external standpoint from which to look down on the world. They have the quantum formalism, but it’s a guide to what we find in our fresh encounters with the world.

### The critical point

Fuchs’s Euglena metaphor has a much broader scope than the other scientific metaphors mentioned above. It is not so much about comparing a piece of the organism to quantum mechanics, but a way of comparing an organism’s adaptation to its world to the experimentalist’s user-manual; in turn, it becomes a story about what the world is.

The Euglena’s tiny whip is a way to grapple with the ontological lesson of quantum mechanics. You might, in fact, call it an “ontologizing” metaphor.

---

**Robert P Crease** is a professor in the Department of Philosophy, Stony Brook University, US; e-mail robert.crease@stonybrook.edu; www.robertpcrease.com; his latest book is *The Leak* (2022 MIT Press). **Gino Elia** is a philosopher of physics who is spending 2026–27 at the Ludwig Maximilian University of Munich, Germany, e-mail gino.elia@stonybrook.edu



# nXQ55i - ideal for Quantum

In the ever-evolving world for scaling quantum technology, innovation is the name of the game—and Edwards is once again raising the bar with its latest breakthrough: the nXQ55i.

This cutting-edge Dry Multistage Roots Pump marks a pivotal advancement in helium pumping performance, redefining what researchers can expect in terms of efficiency, reliability, and precision.

Engineered with a leak tightness of  $5 \times 10^{-8}$  mbar/l/s to address the unique challenges of Helium flow cryostats and dilution refrigerator type applications, the nXQ55i excels where **performance and reliability are absolutely critical.**

Leak-tight design  
*For superior integrity*

Strong light gas performance  
*Ideal for helium applications*

Dry pump design  
*For a clean process*

Long maintenance intervals  
*Reduced Cost of Ownership*



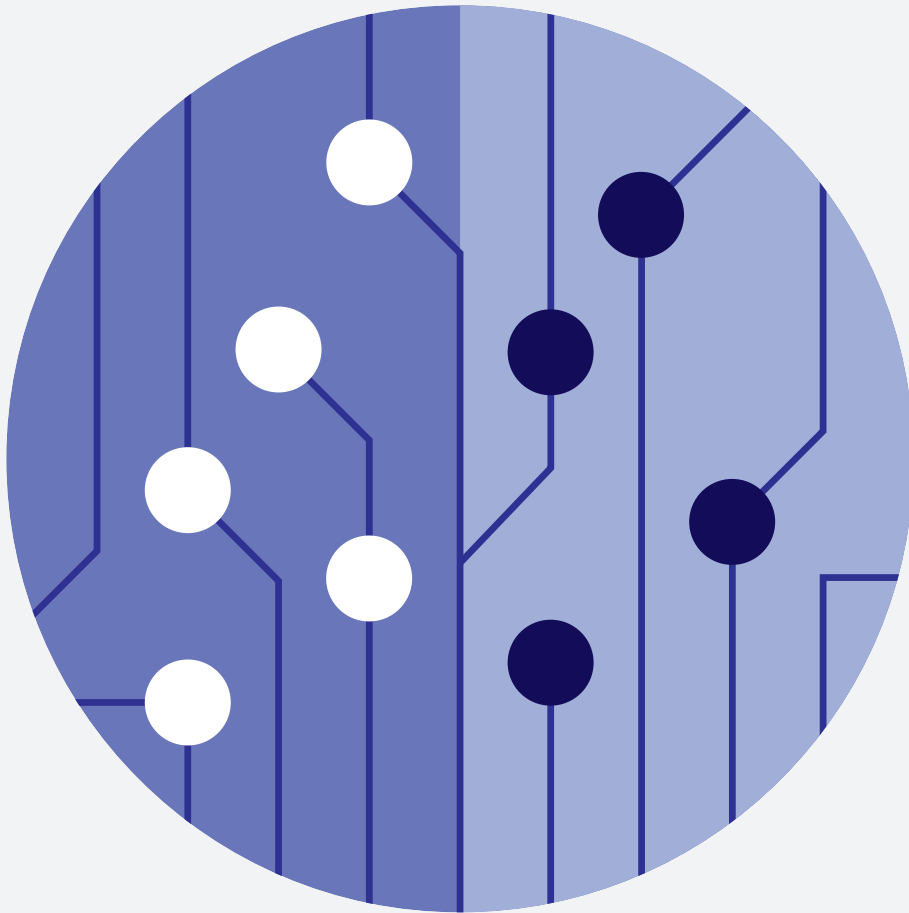

**IPEM** | **IOP** Publishing

# Medical Sensors & Imaging

A new open access journal for trusted innovation in healthcare

## Looking for the right home for your next paper?

*Medical Sensors & Imaging* (MSI) is a new open access journal from the Institute of Physics and Engineering in Medicine (IPEM) providing a dedicated platform for quality research at the intersection of sensing technologies, imaging, modelling and AI for healthcare.



Submit your next paper to MSI and for a limited time, pay no open access fees. Scan to find out more.

# The dark side of lithium batteries

**James Dacey** reviews *The Elements of Power: a Story of War, Technology and the Dirtiest Supply Chain on Earth* by Nicolas Niarchos



Didier Bauwaerts/Reporters/Science Photo Library

In a book about batteries, you might not expect the author to be detained by Congolese secret police because he attempted to meet a rebel warlord whose militia has been linked with cannibalism. But that's exactly what happened when journalist Nicolas Niarchos was doing research for *The Elements of Power: a Story of War, Technology and the Dirtiest Supply Chain on Earth*.

Building on his earlier reporting for the *New Yorker* and other outlets, Niarchos shines a light on the dark underbelly of green tech. He takes the reader from the underprivileged mining communities extracting the raw materials, to the global superpowers profiting from Li-ion technology.

This is a story of geopolitics, deep-rooted inequality, and history repeating itself. In recent decades, governments, corporations and opportunistic intermediaries have jostled for the lion's share of resources in mineral-rich countries. As in colonial times, wealth has again concentrated in the hands of a few, while communities near the resources bear the costs of greed and corruption.

"The world is facing the biggest supply-demand dislocation in living memory with critical metals," writes Niarchos.

In *The Elements of Power*, Niarchos includes the history of Li-ion batteries and their commercialization. Key

scientific figures include British chemist Stanley Whittingham, US solid-state physicist John Goodenough, and Japanese chemist Akira Yoshino, who all shared the 2019 Nobel Prize in Chemistry for their breakthroughs that led to commercial Li-ion batteries.

Whittingham laid the foundations in the 1970s when his work on fast ionic transport in solids led to a cathode made from titanium disulphide that could house (or "intercalate") lithium ions. Goodenough then introduced a lithium cobalt oxide cathode – raising the battery voltage and making it less explosive – before Yoshino took the final step to a commercially viable battery by adding a carbon-based anode in 1985.

Niarchos highlights how Japan failed to capitalize on this early lead. Although Japanese firm Sony released the first Li-ion battery in 1991, production and commercial impetus soon switched to China and South Korea. In fact, at the turn of the millennium, Japan controlled 90% of the Li-ion market, but by 2012 Sony's value had dropped to one-ninth of Samsung's in South Korea.

The electrification of transport has been a key application of China's push for Li-ion batteries – it drives economic growth and tackles air pollution. The speed of progress is striking. In 2018 China produced 1.26 million electric cars over the course of the whole year. By 2024 it

### Unseen riches

Miners extracting cobalt and copper at Ruashi mine in the Haut-Katanga Province of the Democratic Republic of Congo.

was producing a million in a month.

To fuel battery demand, Beijing has steadily strengthened its foothold in places like the DRC and Indonesia. Niarchos highlights the 2007/2008 Sicominex “minerals-for-infrastructure” deal, which was a major, yet controversial, partnership made between the DRC government and a group of Chinese investors. It swapped massive copper/cobalt mining rights in the DRC for \$6bn in Chinese-financed infrastructure, which has been slow to materialize.

Niarchos shows how China’s economic miracle has been fuelled by ruthless geopolitical pragmatism in strengthening its mining deals over decades, but also how the US administration’s manoeuvrings in places like Greenland are an unsubtle sign that it intends to catch up.

Inevitably, Elon Musk and Tesla make several appearances in the book. For example, Niarchos includes how a futuristic Tesla Gigafactory near Berlin, Germany, was attacked by protestors. The episode reveals the conundrum facing progressives in the West who want to go green but in the *right* way, led by the *right* people.

### The people behind the metal

While Niarchos looks at how global superpowers profit from Li-ion technology, it’s his reporting on the sources of critical metals that reveals the truly dark side of the supply chain. Cobalt, often used in Li-ion battery cathodes, is perhaps the starkest example of the problem, and the book gives particular attention to its production and the mining practices in the DRC. More than 70% of global supply comes from the DRC, with most mined in the mineral-rich Katanga region, comprising of the provinces Tanganyika, Haut-Lomami, Lualaba and Haut-Katanga. Extreme poverty is rife, cholera outbreaks are common, and conflict has displaced hundreds of thousands.

One of the book’s strengths is how Niarchos weaves the story of Li-ion batteries with the social history of the DRC. In works like this, the human sections often provide light relief from dense scientific explanations. Here, the opposite is true, as the cycles of violence and exploitation against the Congolese people – which goes back centuries – make for grim reading.

What is now the DRC was colonized in the 1870s by Belgium, and forced labour, starvation, violence and mass death were inflicted on the Congolese people in relation to the ivory and rubber trade. While the country gained its independence from Belgium in 1960, the turbulence of power struggles and civil war has led to deeper corruption, opaque webs of international finance, and foreign magnates whose dealings raise eyebrows among global watchdogs. Today the country seems haunted by its past, trapped by the cruelty of power dynamics and the corrupting influence of promised wealth.

The most resonant pages of *The Elements of Power* describe modern daily life in the Katanga region. Most people see barely a trickle of the vast mineral wealth they help dig up. In 2020 some 74 million Congolese lived below the poverty line of \$2.15 a day, and 43% of children in the country were malnourished.

Many adults and children resort to digging for min-

eral seams using rudimentary tools and minimal safety gear. Referred to as “artisanal” miners by multinational corporations but known as *creuseurs* (French for digger or burrower) in the DRC, they often come from the very poorest stratum of society and do not have the education or the contacts to get jobs with the mining corporations that have official permits to extract the cobalt. Just in Kolwezi – the capital city of the Lualaba Province with a population of nearly 600 000 – an estimated 170 000 of these unofficial miners dig for the black ores, which they then sell to unscrupulous intermediaries.

One of the saddest passages is when Kolwezi resident Françoise Ilunga describes how her husband was crushed and suffocated, along with at least 150 other *creuseurs*, after a tunnel collapsed in the city. Unable to get official jobs, the miners had entered a secluded part of a cobalt mining site without permits or safety gear to find ore to sell so they could support their families. The mine was run by the Anglo-Swiss multinational Glencore (which incidentally had to pay \$700m in 2022 relating to bribery offences in several African nations). Françoise and her family spent two days digging up her husband’s body.

It is easy to see how cycles of poverty have been sustained in the DRC. Niarchos interviews children who say they mined out of necessity for food and clothes. In their villages and towns, conflict still bubbles under. When Niarchos is detained by the DRC’s secret police, he had planned to meet a man called Gédéon, whose militia group, Bakata Katanga, has agitated for a separate Katanga state. Niarchos had heard a rumour that Gédéon was funding himself through artisanal mines. You’ll need to read the book for the full story, but it’s fair to say Niarchos won’t be returning to the DRC anytime soon.

### Save solutions for another day

While *The Elements of Power* touches upon some solutions – such as recycling batteries, and sodium and sulphur-based alternatives to Li-ion batteries – no fully scalable solution is presented. And at times, I found the web of organizations and individuals hard to follow. I’m also a bit of a geology geek so I wish there was a bit more on why the DRC is blessed with so many critical minerals in the first place.

That said, the book feels incredibly timely given the current state of geopolitics. It is essential reading for anyone who cares about the origins of materials powering their phones, cars and many other aspects of daily life in wealthy nations. It shines a light on how difficult it is to know what percentage of critical minerals in your devices has come from ethical sources, despite what tech companies might say.

If there is a key takeaway, it’s that any system-wide solution for greener, ethical mining must consider the entire supply chain. Above all, we should listen to people on the ground sourcing the raw materials that make our shiny new technology possible. A supply chain is only as clean as its grubbiest link.

● 2026 William Collins 480pp £25 hb

James Dacey is a multimedia journalist based in Madrid

Essential reading for anyone who cares about the origins of materials powering their phones, cars and many other aspects of daily life in wealthy nations



# physicsworld

Your favourite *Physics World* puzzles just got an upgrade  
– they're now fully interactive!

Put your skills to the test and see how many you can complete.

Explore the latest puzzles available:  
**[physicsworld.com/puzzle](https://physicsworld.com/puzzle)**





First content now online!

# APS OPEN SCIENCE

## A New Open Access Journal from APS

**Open Access. Experimental Innovation.**

*APS Open Science*, APS' newest peer-reviewed journal, ensures research from every stage of the scientific process receives the recognition it deserves. The journal will:

- Disseminate all sound science, offering rapid publication and seamless transfers from the Physical Review journals
- Welcome unique article types and negative and null results
- Publish papers from a broad scope, including all of physics and related fields

**APS will waive article publication charges  
for papers submitted before 01 September 2026**



Badreddine Assouar  
Chief Editor



Boyana Konforti  
Managing Editor



Claudia Ratti  
Associate Editor



Cosmo Lupo  
Associate Editor



Kohei Nakajima  
Associate Editor



Luiz F. Zagonel  
Associate Editor

**Submit your research today!**  
[go.aps.org/apsos](https://go.aps.org/apsos)



Letters and comments that appear here may have been edited, and do not necessarily reflect the views of *Physics World*. Please send us your feedback by e-mail to [pwld@iopublishing.org](mailto:pwld@iopublishing.org)

## Questions over nuclear power

In response to the blog post by Margaret Harris titled “The dirtiest words in fusion and fission” (23 April 2026), which reported on the Fusion Fest and Nuclear Summit in London in April.

I appreciated the neutral way that Harris covered those aspects of nuclear energy discussed at the meeting. Nearly eight years ago, I spoke at an international conference on nuclear power generation in Hyderabad, India. The title of my talk – “Nuclear fusion as a viable clean energy source: a real possibility or a pie in the sky?” – perhaps indicates my views at the time, and subsequent developments have not given me much reason for changing them.

With ITER now delayed by an additional four or five years, I have concluded that fusion energy is indeed “vapourware”, and I will not be around to see it become a power source. As for fission, we have been using it as a power source for the last 70 years or so. However, the recent trend of small, modular reactors (SMRs) and microreactors is new, and their performance and economic viability have not yet been determined.

As James Walker, chief executive of SMR firm Nano Nuclear Energy said at the Nuclear Summit, the main problem seems to be that most SMRs are neither small nor modular. I am not an economist, but a few years back, a nuclear power industry professional told me that reactors that produce less than 300 MWe are not economically viable.

Hence, SMR designs



**Not so small** The BWRX-300 small modular reactor designed by GE Vernova Hitachi Nuclear Energy takes up around 34 acres of land. The first facility of this type is currently being built near Toronto, Canada.

that started out at less than 100 MWe have now become 300 MWe, or about half the capacity of one of Canada’s CaNDU reactors. These designs are not small in area, either. The BWRX300 being built by GE Vernova Hitachi Nuclear Energy, for example, occupies 34 acres of land.

SMRs are also not modular in the sense we generally envisage them. Initially, we thought that, say, a 300 MWe power station would consist of 10 modules, each of 30 MWe power. That way, we could schedule maintenance so there is no downtime, and if one module quits, we would still have 90% power available. But this is not what SMR designs look like anymore.

Today, for SMRs “modularity” mainly means that we build reactor components (the core, cladding, shielding, heat exchanger and so on) as separate modules and assemble them together, each of which must be in good working condition for power generation. If any single “module” quits or needs maintenance, the reactor will be shutdown.

So-called “micro modular

reactors” in the 5 MWe range are attractive to mines, data centres and other customers for whom cost is not the top concern. That said, if a data centre truly needs 1 GW of power, as Harris’ article suggests, its operators should be looking at advanced Generation IV reactors, not SMRs or microreactors. My students and I worked on a project for a Gen IV supercritical water reactor about 10 years ago – and we’re still waiting to see what Gen IV designs might amount to.

**Chary Rangacharyulu**  
University of Saskatchewan, Canada

## Mentor benefits

In response to Honor Powrie’s article on the importance of mentorship in physics (May pp11–12).

I truly appreciated Powrie’s article, which validated a key experience during my own training. As a particle-physics PhD student working on the CMS experiment at CERN, I took part in the Mentoring@CERN programme, where for

eight months a senior academic worked with me on various professional, non-scientific skills. The experience was life changing.

It let me overcome work-related anxiety and start doing things that I would not have dreamed of before, such as taking a role of responsibility on a CMS committee. Powrie’s article gives welcome visibility to efforts like the Mentoring@CERN programme, which is provided free by staff who are no doubt already busy. I hope it will motivate others to engage or start similar initiatives.

**Cristina Alexe**  
CERN, Switzerland

## Glassy problem

I would like to draw the attention of readers to the plight of the British Society of Scientific Glassblowers (BSSG). When the society was set up in 1960, most universities, if not all, had glassblowing workshops, while many laboratory suppliers offered the same services. Over the years, however, there have been cutbacks in employment so that scientific glassblowers are becoming an endangered species, a fact recognized by the Heritage Crafts charity.

Membership of the BSSG has likewise dwindled to the point that its existence is in doubt. If anyone reading this is a practising glassblower or has an interest in the craft, then please consider joining as a member or associate member. It may be that your career in science has been furthered with the use of scientific glassblowing and now is the time to acknowledge that. The BSSG contact is Matthew Myles (e-mail [bssghonsec@gmail.com](mailto:bssghonsec@gmail.com)).

**Alan Gall**  
Standish, UK

# Delft Circuits: cryogenic RF cable innovations offer a flexible path to quantum scalability

The Dutch manufacturer Delft Circuits is rewriting the rules of I/O cabling technology for full-stack quantum computing systems

As manufacturers in the nascent quantum supply chain turn their gaze towards at-scale commercial opportunities in quantum computing, the scenic city of Delft in the Netherlands is emerging as a heavy-weight player in quantum science, technology and innovation. At the heart of this regional quantum ecosystem is Delft Circuits, a Dutch manufacturer of specialist I/O cabling solutions, which is aligning its product development roadmap to deliver a core enabling technology for the scale-up and industrial deployment of next-generation quantum computing, communications and sensing systems.

In brief, the company's Cri/oFlex® cryogenic RF cables comprise a stripline (a type of transmission line) based on planar microwave circuitry – essentially a conducting strip encapsulated in dielectric material and sandwiched between two conducting ground planes. The use of the polyimide Kapton® as the dielectric ensures Cri/oFlex® cables remain flexible in cryogenic environments (which are necessary to generate quantum states, manipulate them and read them out), with silver or superconducting NbTi providing the conductive strip and



**Flexible thinking, scalable innovation** Delft Circuits has established itself as a one-stop shop for scalable cryogenic I/O assemblies in quantum computing. The company's Cri/oFlex® cabling platform combines fully integrated filtering with a compact footprint and low heatload.

ground layer. The standard product comes as a multichannel flex (eight channels per flex) with a range of I/O channel configurations tailored to the customer's application needs, including flux bias lines, microwave drive lines, signal lines or read-out lines.

“As quantum computers evolve – think

more and more qubits plus increasingly exacting requirements on gate fidelity – system developers will reach a point where current coax cabling technology doesn't cut it anymore,” explains Daan Kuitenbrouwer, co-founder of Delft Circuits. “The key to our story is that Cri/oFlex® allows us to increase the I/O cabling density easily – and by a lot – to scale the number of channels in a single system while guaranteeing high gate fidelities [minimizing noise and heating] as well as market-leading uptime and reliability.”

## Quantum alignment

To put some hard-and-fast performance milestones against that claim, Kuitenbrouwer and colleagues have just published a granular product development roadmap that aligns Cri/oFlex® cabling specifications against the anticipated evolution of quantum computing systems – from 150+ qubits today out to 40,000 qubits and beyond in 2029 (see figure “Quantum alignment”).

“Our roadmap is all about enabling, from an I/O perspective, the transition of quantum technologies out of the R&D lab into at-scale practical applications,” says Kuitenbrouwer. “As such, we studied the development roadmaps of more than 10 full-stack quantum computing vendors to ensure that our ‘guiding principles’ align versus the aggregate view of quantity and quality of qubits targeted by the system developers over time.”

Notwithstanding the emphasis on technology innovation and continuous product improvement, Delft Circuits is also “coming of age” in line with the wider quantum community. Most notably, the company's centre of gravity is shifting inexorably from academic end-users to servicing vendors large and small in the quantum supply chain. “What we see are full-stack quantum computing companies starting to embrace horizontal thinking – which, in our case, means a technology partner able to solve their entire I/O cabling challenge,” explains Kuitenbrouwer.

To gain traction, however, systems integrators at the sub-stack level must, as a given, design their product offering with

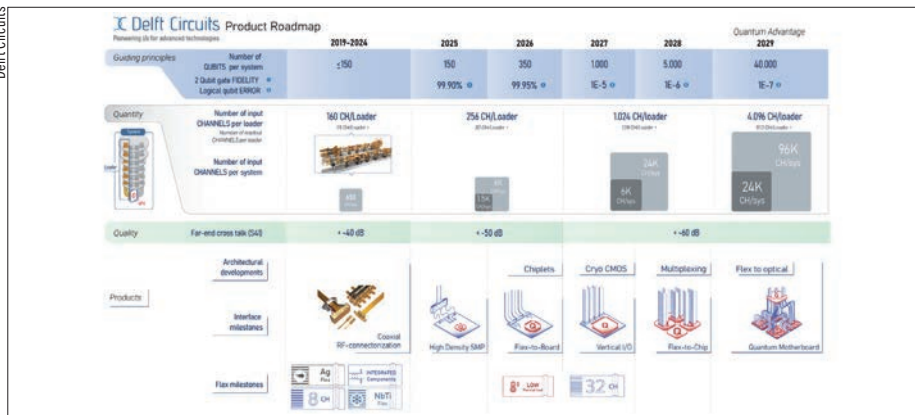

**Quantum alignment** The new product development roadmap from Delft Circuits starts with the guiding principles, highlighting performance milestones to be achieved by the quantum computing industry over the next five years – specifically, the number of physical qubits per system and gate fidelities. By extension, cabling metrics in the Delft Circuits roadmap focus on “quantity”: the number of I/O channels per loader (i.e. the wiring trees that insert into a cryostat, with typical cryostats having between 6–24 slots for loaders) and the number of channels per cryostat (summing across all loaders); also on “quality” (the crosstalk in the cabling flex). To complete the picture, the roadmap outlines product introductions at a conceptual level to enable both the quantity and quality timelines



**Kuitenbrouwer** “Cri/oFlex® allows us to increase the I/O cabling density easily – and by a lot.”

industrial metrics front-and-centre – for example, scalability, manufacturability, reliability, cost per I/O channel and second-sourcing. Equally important is the need to forge long-term vendor-customer relationships that often move beyond the transactional into the realm of co-development and collaboration – though all against a standardized package of cabling options.

“We integrate Cri/oFlex® with cryostats that have relatively standard vacuum feedthroughs and thermalization – more or less the same across the board,” says Kuitenbrouwer. What changes is the type of qubit – superconducting, spin, photonic – which in turn determines the configuration of the I/O line and where to place the attenuators, low-pass filters and IR filters. “This is something we can adjust relatively easily – at high volume and high reliability – with the whole I/O package installed and tested at the customer premises,” he adds.

### Timing is key for quantum advantage

Commercially, Delft Circuits is already making real headway, getting “in the door” with many of the leading developers of quantum computing systems in North America and Europe. One of the main reasons for that is the ability to respond to customer requirements in an agile and timely fashion, argues Sal Bosman, a fellow co-founder of Delft Circuits.

“We work on the basis of a very structured design process, playing to our strengths in superconductor fabrication, integrated



**Bosman** “Currently, we are the only industrial supplier able to deliver flexible circuits of superconducting materials at scale.”

## Location, location, location



**Cryogenic integration** Delft Circuits can supply fully pre-assembled loaders with Cri/oFlex® cabling inside.

Delft Circuits sits within a thriving regional cluster for quantum science and technology called Quantum Delta Delft, which is centred around the canal-ringed city of Delft between The Hague and Rotterdam.

Formed in 2017 and initially located at the Faculty of Applied Sciences at Delft University of Technology (TU Delft), Delft Circuits has since grown as an independent company and is now based in the historic Cable District, where its facilities include a dedicated fabrication, pilot-production and testing area.

TU Delft is itself home to a high-profile interfaculty research institute called QuTech, a collaboration with the Netherlands Organisation for Applied Scientific Research (TNO) that’s tasked with developing full-stack hardware and software layers (including enhanced qubit technologies) for quantum computing and quantum communications systems.

Alongside this academic powerhouse, the Delft region has seen the emergence of other quantum tech start-ups like QuantWare (quantum chips), Qblox (control electronics) and Orange Quantum Systems (test solutions). All three companies work closely with Delft Circuits as part of the ImpaqT UA cooperative, a joint effort to develop open standards and interoperable technologies that enable system integrators to build quantum computing hardware stacks from off-the-shelf components.

“The ImpaqT UA story is ongoing,” explains Kuitenbrouwer. “As partners, we are super-complementary and collaborate closely to shape the future of quantum computing.” That’s why the new development roadmap is so important for Delft Circuits: to communicate a vision from the “component layer” up the value chain to the full-stack quantum computing companies.

As well as the talent pipeline that comes with proximity to TU Delft and QuTech, Quantum Delta Delft is home to TNO’s Quantum Information Technology Testing (QITT) Facility, which enables European companies to evaluate their cryogenic or non-cryogenic quantum devices and software in a full-stack quantum computing set-up.

microwave components and cryogenic engineering,” Bosman notes. “We have also developed our own in-house software to simulate the performance of Cri/oFlex® cabling in full-stack quantum systems. No other vendor can match this level of customer support and attention to detail.”

Right now, though, it’s all about momentum as Delft Circuits seeks to capitalize on its first-mover advantage and, what Bosman claims, is the unique value proposition of its Cri/oFlex® technology: a complete and inherently scalable I/O solution with integrated flex cables incorporating filters and high-density interconnects to quantum chips or control electronics.

With this in mind, the company is busy constructing a new 750 m<sup>2</sup> clean-room (with an option to double that footprint) alongside its existing 1000 m<sup>2</sup> in-house pilot-produc-

tion and test facility. “Currently, we are the only industrial supplier able to deliver flexible circuits of superconducting materials at scale,” concludes Bosman.

“Over the next two to three years,” he adds, “we have a credible opportunity to grab significant market share when it comes to cabling I/O for quantum. Watch this space: a lot of customers are already coming to us saying ‘we don’t want to buy more coax, we want to work with you.’”



[www.delft-circuits.com](http://www.delft-circuits.com)

This article was written by *Physics World* on behalf of Delft Circuits. Read more on [physicsworld.com](http://physicsworld.com).

# Artemis II returns humanity to the Moon

On 1 April 2026 Artemis II launched humanity back to the Moon after 54 years of absence. The world was gripped with excitement as the NASA mission took its crew further from Earth than any human has been before. **Keith Cooper** follows the mission's journey and explores what comes next for humans in space

**Keith Cooper** is a freelance science writer

After 54 years, numerous failed starts and countless abandoned dreams, earlier this year humanity finally returned to the Moon in an epic 10-day flight that gripped the planet. The Artemis II mission and its four astronauts – mission commander Reid Wiseman, pilot Victor Glover and mission specialists Christina Koch and Jeremy Hansen – gave us something to smile about during a dark time of global geopolitical turmoil.

The primary objective of the mission was to fly a crew around the Moon, to demonstrate and test the systems needed to support astronauts in deep-space exploration. In doing so, Wiseman, Glover, Koch and Hansen ventured farther from our planet than any human has ever gone and saw things on the lunar surface that no human eye has seen before.

That the crew did not land and walk on the Moon did not diminish the enthusiasm for the mission. Through today's online world, the astronauts were able to share their own excitement with the millions watching from Earth with such relatability that the popularity of the mission was cemented in the history books.

Moreover, their voyage and safe return has paved the way for future Artemis missions. These will not only see astronauts set foot on the lunar surface for the first time since 1972, but also include building a permanently crewed outpost at the lunar south pole.

On 1 April 2026 spectators on the ground, millions online and even the crew of the International Space Station (ISS) watched as Artemis II blasted off from pad 39B at the Kennedy Space Center in Florida at 6.35 p.m. EDT.



## The astronauts of Artemis II

The Artemis II crew broke records by travelling further from Earth than any humans had before. But they also made history by including the first person of colour, the first woman and the first Canadian to go beyond low Earth orbit, and to travel around the Moon. Here's who they are:



### Reid Wiseman – mission commander

A former US Navy fighter pilot and test pilot, Wiseman was selected as an astronaut by NASA in 2009 and flew to the International Space Station (ISS) in 2014 as part of Expedition 41, where he took part in space walks. He was chief of the Astronaut Office between 2020 and 2022 before being made mission commander on Artemis II. A crater on the Moon seen by the crew of Artemis II has been named after his late wife, Carroll.



**Victor Glover – pilot**



Having joined NASA’s astronaut corps in 2013, Glover’s first venture into space was as pilot on the first post-certification flight of SpaceX’s Crew Dragon capsule to the ISS. As part of Expeditions 64 and 65, Glover performed four space walks during his time on the station. Like Wiseman, he is also a former US Navy pilot and test pilot.

**Christina Koch – mission specialist**



In 2019 Koch spent 326 days onboard the ISS as part of Expeditions 59, 60 and 61, setting the record for the longest continuous spaceflight for a female astronaut. During this time she also participated in the first all-female spacewalk. Prior to being chosen as an astronaut in 2013, Koch worked as an electrical engineer at NASA’s Goddard Space Flight Center, and spent time in Antarctica at the Amundsen-Scott South Pole Station and Palmer Station.

**Jeremy Hansen – mission specialist**



A colonel in the Royal Canadian Air Force, Hansen became an astronaut for the Canadian Space Agency in 2009. His training included taking part in the European Space Agency’s CAVES programme – spending time living underground in Sardinia – and NASA’s NEEMO 19 seven-day undersea mission. Artemis II was Hansen’s first flight into space.

**Earthset**

On 6 April 2026 the Artemis II crew photographed the crescent Earth slipping behind the limb of the Moon as *Integrity* prepared to loop around the far side.

## 1 Journey to the Moon

NASA/JSC/Goddard

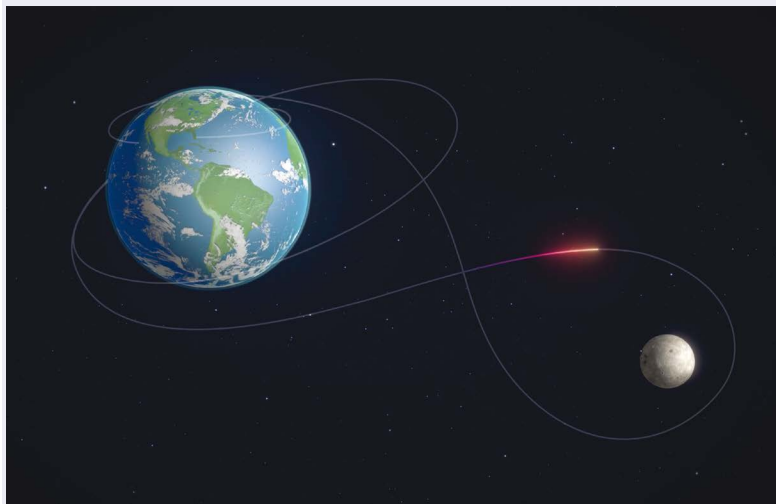

Trajectory for Artemis II's flight. After being launched by a Space Launch System rocket from Kennedy Space Center in Florida, the Orion spacecraft completed two orbits of Earth and then flew around the Moon in a figure-eight pattern before returning to Earth.

At launch, the four crew members were safely enclosed in their home for the next 10 days – the Orion spacecraft they had named *Integrity*. In turn, *Integrity* sat atop NASA's gigantic Space Launch System (SLS), a rocket more powerful than the mighty Saturn V. Standing 98 m tall, the SLS was driven by four RS-25 liquid propellant engines and supported by two solid-rocket boosters, producing in excess of 39 000 kN of thrust at lift-off.

It was only the second flight of the SLS following 2022's Artemis I, an uncrewed Moon-orbiting mission to test the SLS rocket and Orion spacecraft. Yet the Artemis II launch was flawless, with the thunderous roar deafening spectators and astounding the assorted news media present.

As the rocket left the atmosphere, the solid-rocket boosters, protective panels and launch abort system (there in case of ascent emergencies) were all successfully jettisoned, followed by the core stage of the SLS. Next, using the interim cryogenic propulsion stage (ICPS) or upper stage – fuelled by a liquid hydrogen/oxygen mix and powered by a single RL10 engine providing 110 kN of thrust – the mission performed a series of manoeuvres to raise its altitude, reaching an orbital elevation of 74 000 km.

Following that, the upper stage was separated; but before leaving it (and Earth) behind, the astronauts used it as part of their demonstration tests, which included showing they could manually pilot *Integrity*. While in high orbit, the mission also deployed four cubesats – one each from Argentina, Germany, Saudi Arabia and South Korea – designed to study the effects of space radiation from the Sun and in Earth's Van Allen radiation belts, and how electrical systems perform in such radiation-drenched environments.

With all that done, it was time to leave Earth's orbit. On day two, the engine of the service module (constructed by the European Space Agency (ESA)) performed the trans-lunar injection burn – firing for almost six minutes to propel the capsule and crew out of Earth orbit and towards the Moon. Artemis II would not orbit the Moon, but swing around it and head back to Earth, following a

## The astronauts had a list of 35 targets to find and record that had been selected by the Artemis II science team

flight path known as a free-return trajectory. This means that after the trans-lunar injection burn, *Integrity* coasted for four days through space with only occasional minor course corrections to keep the Moon dead ahead. No further engine burns were required in order to get home (hence “free”) – their trajectory used lunar gravity to naturally slingshot them around the Moon while Earth's gravity drew them back home. On a diagram, *Integrity*'s trajectory looks like a figure of eight, which follows gravitational gradients between the Earth and the Moon (figure 1).

### Close encounter

On 6 April the mission flew round the Moon just once, giving the crew a seven-hour fly-by observation period of both the near and far sides.

The astronauts' view of the lunar surface was “amazing” in the words of mission commander Wiseman. “The four of us have looked at the Moon our entire lives and the way we are responding to what we're seeing out the window is just like we're a bunch of kids up here. We cannot get enough of this,” he radioed back to Earth.

For much of the fly-by, the four astronauts were like space paparazzi, taking it in turns to photograph the Moon. Although lunar science wasn't part of the mission, they had a list of 35 targets to find and record that had been selected by the Artemis II science team led by Kelsey Young from NASA's Goddard Space Flight Center. Among them were impact craters with radial streaks of ejecta that can help planetary scientists understand how craters evolve over time; and a bright swirly feature known as Reiner Gamma that contains a magnetic anomaly and is a possible future landing site for robotic explorers.

The astronauts also targeted parts of the far side that had never before been seen by human eyes because they had been in darkness during the Apollo missions. They were aided in their efforts by a custom-designed app, called the Lunar Targeting Plan, which contained information on the targets, what features to look out for, and how to correctly photograph them – there were even prompts for discussions about what they were seeing.

Some have suggested that the crew's efforts were more about aesthetics than science, since the entirety of the Moon has previously been mapped by past missions. These include Japan's Kaguya orbiter, the spacecraft in India's Chandrayaan programme and Europe's SMART-1 mission back in 2003. Indeed, none have mapped the Moon as comprehensively as NASA's Lunar Reconnaissance Orbiter (LRO), which launched in 2009 and to this day continues to map the entire lunar surface to 100-metre resolution, and in some places reaches an

NASA



**Moonwatch**

The double-ringed structure of the Orientale basin, with Mare Orientale in the middle.

NASA



**Eclipse**

The crew of Artemis II witnessed a 54-minute-long total solar eclipse from the far side of the Moon. The origin of the halo of light remains unclear: is it caused by the solar corona, the zodiacal light, or a combination of the two?

unprecedented half-metre resolution.

However, Amanda Hendrix, who is director of the Planetary Science Institute (PSI) in Arizona and who works on LRO, disagrees that lunar science wasn't a part of the Artemis II mission.

"I think there was science to do on the fly-by," she says. While LRO's cameras catch a lot on the lunar surface, particularly how features seem to change with the shortening and lengthening of shadows throughout the lunar day, there's something very crucial that is missing. "LRO's

instrumentation is limited," explains Hendrix. "Its cameras don't have that many filters, so we don't get that much colour information."

As it turns out, the Moon isn't just a boring silver-grey sphere, but a world of many subtle colours, which Apollo 17 astronaut and geologist Harrison Schmitt discovered in 1972, when he found orange regolith made of volcanic beads rich in titanium.

"What the Artemis II crew brought is the spectral coverage that they could see with their eyes that we don't

**New perspective**

On day six of the mission, *Integrity* on the left, with the crescent Moon and Earth over 400 000 km away in the distance.

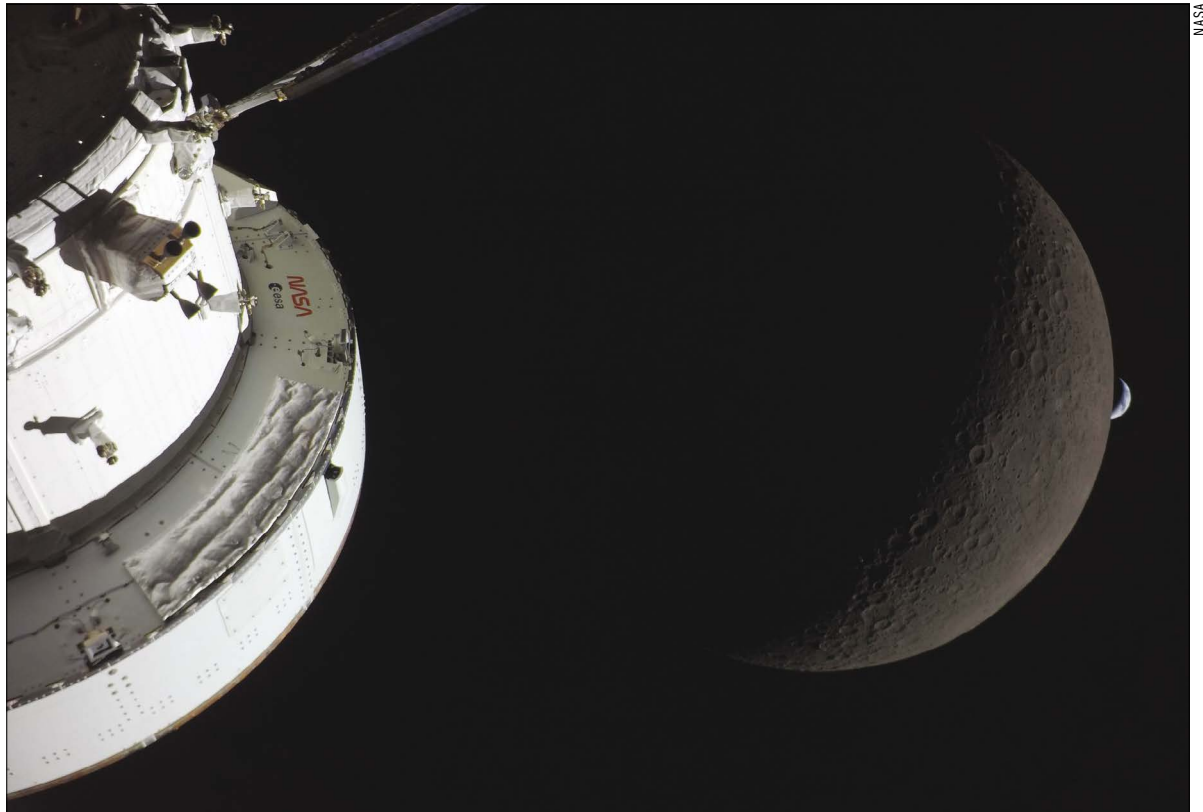

NASA

have with LRO,” says Hendrix. “Plus, we could hear the astronauts talking about how impressed they were with the change in lighting geometry as the spacecraft went around behind the Moon, and how the day/night terminator moved across the surface. So I do think there is new scientific information there.”

**The far side**

Most of the science targets were found on the far side, including the mighty Orientale impact basin, which is located on the limb of the Moon as seen from Earth. (The limb is what we call the edge of the Moon when we look at it in the sky, but we can’t call it an edge since the Moon, as a sphere, doesn’t have an edge. Features on the limb are foreshortened because of perspective as the lunar surface curves away from us.) Thought to be the youngest of the Moon’s large impacts, Orientale features a lunar sea (known as a mare) at its centre, and a stunning double-ring structure at its edge. The exterior ring has a diameter of 930 km, making it one of the largest impact sites in the entire solar system.

“What really struck me is that this was the first time that humans themselves saw so much of the Moon and I think a lot of people don’t really appreciate that,” says Jeffrey Andrews-Hanna, a planetary scientist at the University of Arizona’s Lunar and Planetary Laboratory. “A great example is the Orientale impact basin. We have an incredible amount of data from orbiting robotic spacecraft, but humans had never actually laid eyes on so much of it until now. The Artemis II astronauts had a prime view looking on the surface and seeing the basin in its entirety.”

At one point shortly after the closest approach – which saw the astronauts get to within 6545 km of the lunar surface – they witnessed the Sun spectacularly fall into total eclipse behind the Moon. Then, as *Integrity* was cast into the Moon’s shadow, the crew saw five remarkable events

– flashes of light as meteorites slammed into the surface, gouging out small new craters. The flashes were so fast that the crew were unable to catch them on camera, but they knew to be on the lookout for them nevertheless.

Lunar impacts have been sporadically witnessed before by spacecraft and amateur astrophotographers, but this was the first time it has been possible to ascertain the rate of impacts occurring on the Moon.

“To have seen five of them during that short time frame tells you the rate at which they must be happening all over the Moon, whether you can see them or not,” says Hendrix. “That’s important for telling us how much material is still out there impacting not only the Moon but also Earth, or at least the top of our atmosphere.”

Looking to future Artemis missions that will land on the Moon (currently planned from 2028), Andrews-Hanna sees a way in which the study of meteorite impacts can be enhanced by seismometers placed on the surface. “Understanding the impact flux is important,” he says. “And there’s a lot that can come from linking an impact that is seen with the seismic waves that are measured.”

A seismometer can give some indication of the size of the impacts, providing information about the mass of the meteorites impacting the Moon as well as their frequency. The seismic waves can even be used as probes into the Moon’s interior structure.

**Back to Earth**

The farthest that *Integrity* got from Earth was 406 771 km, breaking Apollo 13’s distance record of 401 171 km. While behind the Moon, the crew were out of contact with Earth for 40 minutes (as planned), far from home and completely alone.

That perfect isolation would not last long, and soon *Integrity* was embarking on the journey home, to arrive on Friday 10 April. Yet even if NASA and the Artemis II

NASA/Josh Valcarcel



crew didn't show it, there was some nervousness ahead of that return.

During Artemis I the heat shield on the empty Orion capsule suffered serious damage, cracking to the point that large chunks of the heat-resistant Avcoat material ripped dangerously away in temperatures of 2760 °C while plummeting through Earth's atmosphere. Upon investigation, NASA scientists found that the problem was triggered by the skip guidance entry technique they had used to return Orion to Earth, which involves dipping the capsule in and out of the atmosphere so that atmospheric drag helps slow the re-entry.

In ground tests to simulate the technique, the scientists had used heating rates that had allowed a permeable char layer to form and ablate, releasing gases produced by the Avcoat layer. But in reality, dipping in and out of the atmosphere resulted in less severe heating and slower char formation. Gases accumulated in the Avcoat layer and could not escape, causing cracking.

Obviously, something needed to be changed for Artemis II. Rather than modify the heat shield that had already been built, NASA decided to change the re-entry profile. *Integrity's* trajectory was made steeper, reducing time spent in the part of the atmosphere where Artemis I had problems – however, this would make it the fastest atmospheric entry ever attempted by a crewed spacecraft.

During the 13-minute fall from the sky, the heat shield held up well, staying hot long enough to release the gases. Eleven parachutes in total were deployed, slowing the capsule from 40 230 km/h while 120 km above the Earth, to 523 km/h at 8 km altitude. By the time the main parachute unfurled, *Integrity* was gently drifting down at less than 32 km/h for a successful splashdown in the Pacific Ocean near San Diego.

### From II to V

Artemis II was a success, proving that we can send humans back to the vicinity of the Moon. Artemis III



**Safe travels** (Left) *Integrity* splashes down safely into the Pacific Ocean. (Right) The crew of Artemis II celebrate their flight around the Moon. The mission was followed by millions of people around the world.

was originally planned to finally land on the lunar surface again, but it has now been repurposed for practising docking and rendezvous procedures in low Earth orbit, just as Apollo 9 did following Apollo 8's triumphant flight around the Moon. Artemis IV, planned for early 2028, is currently the mission that will land, and hopefully later that year Artemis V will begin construction of a lunar outpost at the South Pole–Aitken Basin, among permanently shadowed craters that harbour water-ice.

After Artemis II, landing on the Moon doesn't feel as far away as it did. Certainly, Wiseman is more optimistic now than he ever was. "I'm going to eat these words, but [landing on the Moon] is not the leap I thought it was," he told journalists at a media conference in Houston a week after splashdown. "Once we were around the Moon in a vehicle that was handling great, if you'd given us the keys to a lander, we would have taken it down and landed on the Moon. It's going to be extremely technically challenging, but it is absolutely doable, and doable soon."

While science was not the priority for Artemis II, the scientific community is already positioning itself to make the most of returning to the Moon. Hendrix points out that three researchers from PSI have been selected as participating scientists for Artemis IV. Meanwhile, tangential to the Artemis programme is the Commercial Lunar Payload Services (CLPS), in which NASA is working with private contractors to build small landers that can take scientific experiments to the Moon. Although their success in landing has been somewhat mixed so far, it opens the Moon up to a wider range of scientists.

That's important, says Hendrix, because there's less grant money coming from NASA, which has seen its budget remain more or less the same while shouldering the burden of more large-scale missions.

"There is concern in the planetary science community that opportunities have been shrinking and it is because the budget hasn't increased enough over the past couple of decades to accommodate all the programmes that are

After Artemis II, landing on the Moon doesn't feel as far away as it did

## Visiting our orbiting companion

NASA/Bill Anders

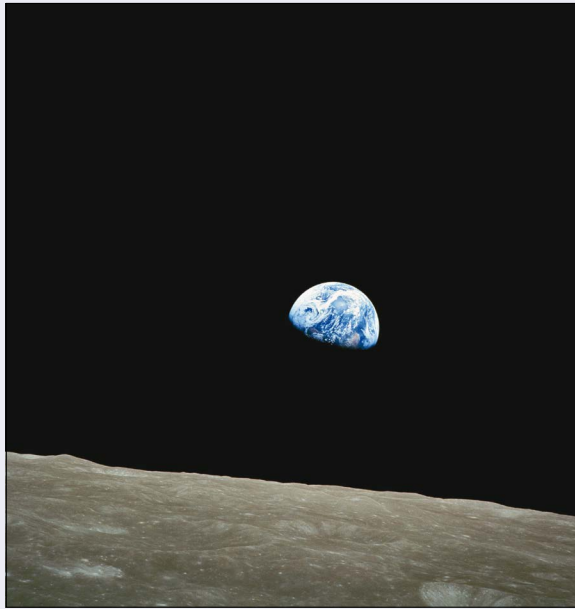

**Earthrise** This famous photograph of Earth with the Moon as foreground was taken on 24 December 1968 during the Apollo 8 mission.



NASA/Harrison Schmitt

**Last man on the Moon** Gene Cernan walks on the Moon in December 1972 during the Apollo 17 mission, of which he was mission commander.

The first crewed mission to the Moon took place in December 1968 when NASA's Apollo 8 entered lunar orbit. Over the next four years, the US sent another eight crewed spacecraft, including the historic Apollo 11 mission that saw Neil Armstrong take humanity's first steps on the Moon.

But we then stopped sending people to our rocky satellite. The Apollo missions were cancelled due to budget costs and changing political priorities, while the Soviet Union's efforts to land cosmonauts on the Moon stalled on the launchpad with the failure to develop their N1 heavy lift rocket. Many uncrewed missions from around the world have impacted, orbited, flown by or landed on the Moon, but – until now – none have had human passengers, leaving Gene Cernan as the last person to set foot on the Moon on 13 December 1972 as part of the Apollo 17 mission.

happening,” says Hendrix. There is also great uncertainty in the US science community around funding and budget changes under the current administration. “Planetary scientists can at least do some science on the Artemis missions as part of the landing science team, and they can be part of the science teams for instruments on CLPS missions, and those are the bulk of the opportunities now.”

The US is not the only country with its sights set on the Moon. China is also hoping to send astronauts – or taikonauts – by 2030. They will travel in the Mengzhou seven-person spacecraft, which is currently scheduled to do its first orbital uncrewed test flight in September 2026. The corresponding lunar lander, called Lanyue, is also under development. In the meantime, China has been sending regular robotic missions to both the near and far side of the Moon, and has brought precious lunar samples back to Earth. These missions have involved some – albeit limited – international co-operation, particularly with European scientists who have had experiments flown on the missions.

### Inspiring the world from the Moon

Since the safe return of the Artemis II crew, the reaction has been as philosophical as it has been admiring of the technical feats of the mission. This was especially notable during the astronauts' press conference, in which they discussed not the sights they had seen, but the way the

mission had brought the whole world together in support.

“When we came home, we were shocked by the global outpouring of support, of pride, of ownership of this mission,” admitted Wiseman. “The four of us wanted to go out and do something that would bring the world together.”

Public interest is vital if the Artemis programme is to continue being funded, explains Hendrix. “The whole of planet Earth was brought along with them, as we watched on our screens,” she says. “Getting everybody on Earth behind these missions is important, especially the people who make the budget.”

When Apollo 8 took three astronauts around the Moon for the first time during Christmas week of 1968, it brought the American public together during a time of national strife because of the Vietnam War. The famous “Earthrise” photograph taken during the mission also became a rallying cry for the burgeoning environmental movement.

The global circumstances around the time of Artemis II's launch were not dissimilar, with wars in South-West Asia and Ukraine continuing against a backdrop of impending environmental disaster and social and political strife. Perhaps our return to the Moon will help bring people back on Earth together once again.

● See p5 of this digital magazine for more about the Artemis II mission in the latest episode of the *Physics World Stories* podcast – or subscribe in your podcast app

# VEXLUM

## The laser platform built for scalable quantum technology



Quantum technologies require compact, stable, high-performance lasers — across more than 100 different wavelengths.

Vexlum's new VXL® platform delivers watt-level single-frequency output in a compact 2-liter architecture, reducing system volume by more than 20× compared to traditional laboratory setups.

Designed for quantum computing and optical atomic clock applications.

Contact [sales@vexlum.com](mailto:sales@vexlum.com) for further information!

**20x Smaller System  
Volume**

**350-2150 nm  
Wavelength Coverage**

**Single-Frequency  
Watt-Level Output**

**Designed for  
Quantum Deployment**

### STINGER® Q SERIES

LHe-FREE CLOSED-CYCLE  
MODULAR SUPPLY SYSTEM



### ULV Q SERIES

ULTRA LOW VIBRATION  
HIGH-POWER COOLING

Advanced noise dampening  
to remove Acoustic, Magnetic,  
Electrical, Vibrational,  
and Thermal interference

Flexible, ultra low  
vibration transfer line  
( < 10 nm displacement)

*pictured here with  
UHV cryostat*

Non-stop 4K LHe-free cooling  
for cryostats, detectors, and  
hybrid quantum setups

Provides up to  
**1.5 W @ 4.2 K**

*Upcoming:*  
**3 W @ 4.2 K**

Provides up to  
**5 W @ 4.2 K**

*Upcoming:*  
**10 W @ 4.2 K**

Transfers 100%  
of the cooler's  
2<sup>nd</sup> stage capacity

No mechanical  
contact!

“Gas Gap” design  
physically isolates the  
engine to **cut vibration**  
at the main source

**MEASURED DIRECTLY AT  
SAMPLE MOUNT POINT**

LEARN MORE ONLINE AT  
[WWW.COLDEDGETECH.COM](http://WWW.COLDEDGETECH.COM)

ColdEdge



# A critical mass of physics talent

What happens when 14 000 physicists converge at one point in time and space? **Candice Chua** and **Margaret Harris** report from the American Physical Society's Global Physics Summit – billed as the world's biggest physics meeting – while **Victoria Merriman** describes her experiences at an official satellite event in Cameroon

**Candice Chua** is a PhD student at Harvard University and the Massachusetts Institute of Technology, US, and a member of the *Physics World* student contributor network. **Margaret Harris** is an online editor for *Physics World*. **Victoria Merriman** is editor engagement manager at IOP Publishing in Bristol, UK

Many-body physicists like myself are fascinated by large ensembles of interacting particles, trying to decipher their collective behaviour. Such systems are notoriously difficult to simulate, yet they underpin superconductivity, superfluidity and other strange phenomena. But when I arrived in Denver, Colorado, US in March to attend my first-ever Global Physics Summit (GPS), I was in the midst of a huge and very different kind of many-body system.

Organized by the American Physical Society (APS), the GPS combines the APS's previously separate March and April meetings into what it claims is the largest physics conference in the world. Attended by an estimated 14 000 people from every area of physics, the GPS is a chance to meet colleagues, hear about breakthrough research, mingle with companies at the exhibition and perhaps even land a dream job.

So what characteristics, behaviour and phenomena did

I glean from this uniquely human many-body system? On the first day of the event, I found myself part of a huge crowd collectively moving towards the cavernous Colorado Convention Center for an 8 a.m. start. Inside, the conference was humming with its own emergent dynamics, with lines forming around coffee stations and people bustling to find their way to wherever they were going.

As the day progressed, I was faced with repeated indecision trying to choose between over 80 simultaneous sessions. Some housed the APS's infamous "blitz" talks, with speakers racing to pack the maximum number of graphs and equations into their allotted 10 minutes. Having barely enough time to write down the takeaway messages, I tried, often in vain, to fill my memory as quickly as possible.

Other sessions featured longer talks on hot topics in physics. By that first evening, my mind was swimming with notions of scalable quantum computing, concerns



about physics funding, opportunities for public engagement and worries about the infiltration of AI slop into every corner of the scientific process. These sessions were a necessary reminder that science is not performed in a vacuum.

### Collective behaviour

It was almost a relief, therefore, when I sank in to some purely technical sessions on ultracold atomic gases. Cooled to only a fraction of a degree above absolute zero, ultracold atoms provide physicists with a clean and controllable platform for studying quantum many-body physics. At its heart, this physics is governed by interparticle correlations: bosons bunch together, while fermions stay apart.

If physicists were particles, our reputation for being anti-social might suggest that we'd be fermions. But give us an APS lanyard and physicists are transformed, as I discovered at dinner one evening. I'd requested a table for one but, barely a moment later, I was joined by a physicist I'd never met before. The evening unfolded behind pleasant chatter about 2D materials and the lack of vegetables in our travel diets.

Two tables down sat a professor whose work I admired. Steeling myself, I built up the courage to walk past his

table and say hello. As I did, I mentioned that I'd met him once last year and, despite his blank looks, kept talking until he agreed that he remembered and that it was nice to run into each other again. Whether the professor was telling the truth, I will never know.

But one thing's for sure: without an APS lanyard, I probably would not have dared that chat. In fact, those individual conversations are what I valued most of all in Denver. Just as a high-resolution "quantum-gas microscope" in my lab lets me see individual atoms that are impossible to view with bulk-imaging techniques, so those one-to-one conversations provided far richer information than large sessions passively attended.

### Getting a vibe for AI

One beauty of the GPS is you never know what you might find out, as I discovered when I joined a crowd of other early-stage physicists for a session entitled "Navigating the AI revolution: future-proofing your science career". We might have all been searching for practical career advice, but what we ended up with was something more philosophical than any of us could have bargained for.

The session began with Malachi Schram of the Pacific Northwest National Laboratory and Hilary Egan of the National Laboratory of the Rockies delivering back-



## Machines – unlike humans – can visualize higher dimensional spaces, hold far more information in memory and process more complex equations

to-back talks full of similar rhetoric, emphasizing the fast-paced development of AI used for specialized tasks in science, such as detecting equipment failure or identifying ways of retrofitting older buildings. But the third speaker, Matthew Schwartz, took his optimism about AI far further in a punchy presentation.

Schwartz, who is a theoretical physicist at Harvard University, predicted that large language models (LLMs) will surpass human intelligence in five years. “There’s definitely exponential growth of the intellectual capacity of these [large language] models as a function of time,” Schwartz said, using the number of model parameters as a proxy for intelligence. “The machines are still growing by roughly 10 times each year, and we” – he paused for dramatic effect – “are not growing much smarter.”

After the laughter had subsided, Schwarz went on to explain how machines – unlike humans – can visualize higher dimensional spaces, hold far more information in memory and process more complex equations. “We are not the endpoint of intelligence,” Schwartz said. “We are only the smartest things to evolve on Earth so far.” Humans, he suggested, may simply be incapable of understanding long-standing physics problems such as a theory of everything. Cats, after all, will never understand chess.

If the talent of physicists exists on a bell curve, Schwartz claimed we can push it higher on the talent axis. “If we use AI augmentation,” he claimed, “we can get 10 000 Einsteins a century instead of one.” What the world will do with 10 000 Einsteins is, however, anyone’s guess. Indeed, the next speaker, Matthew Ginsberg from Google Deepmind, expressed strong disagreement over AI’s ability to advance physics.

“Asking questions is the essence of being a good physicist and, at least so far, 100% our domain,” he argued. Underlining the importance of human creativity,

Ginsberg reminded us that LLMs are only good at generating the consensus response to hard questions. “You are the best physicist when you give the not-consensus answer, which is what AI is incapable of doing.” We’re not being “exponentially eaten away”, he insisted. “I remain hopeful that we have a role to play.”

In a concluding panel discussion, Schram, Egan, Ginsberg and Schwartz seemed to converge on the idea that the human contribution to physics has to do with what some called “taste,” others “creativity,” or “asking good questions” (seemingly, questions that humans find interesting). However, over the three-hour session, Schwartz and Ginsberg independently predicted that AI may develop the ability to ask good questions in the next decade.

Could this undermine the main argument for the value of humans in science? Does there exist a deeply human role in the physics of the future, or is “vibe physics” on the 10-year horizon? Perhaps only time will tell.

### Meeting of minds

Attending the GPS was thrilling, a stark contrast to my usual days as a graduate student working in a dark room amid the whirr of machines. For a week, my routine was temporarily replaced by a constant hustle between sessions spanning a gamut of topics, the constant development of new ideas to take back to my lab, and spontaneous encounters with old and new friends.

By the end of the week, I was starting to recognize people I’d already met over the few days prior. Given the sheer size of the GPS, I viewed every reunion or simple “Oh, hi!” as a miracle. Some people shared their personal journeys navigating the hardships and uncertainties of today’s world. Others discussed the trade-offs and uncertainties in their experimental results. Perhaps the most fulfilling and deeply human conversations were the spontaneous ones that arose outside the doors of sessions that we had meant to be in.

When Friday rolled around, the city emptied as quickly as it had filled. For me, I retreated into the sunny Boulder mountains, mulling over the lingering resolution of singular people whose shared words and ideas were now intertwined with my own. Ignoring my fear of getting lost, I followed my instincts deeper into the dry heat of the afternoon, one step at a time.

**Candice Chua**

## A gathering storm

With several dozen talks taking place at any one time, figuring out what to attend at the GPS is a challenge. On the third day of the conference, my choice was particularly stark. Should I depress myself by attending a session entitled “The crisis in American science”? Or should I restore my faith in humanity by finding out “How early-career physicists are solving society’s greatest challenges”?

A quirk of scheduling – or an APS organizer with a dark sense of humour – meant the two sessions were practically next door, so I decided to oscillate between them, hoping to strike a balance between cheer and gloom. The first speaker in the early-career session was Rosimar Rios-Berrios, a physicist at the US National Center for Atmospheric Research (NCAR), which is located up the road from Denver in Boulder.

NCAR is home to the iconic, adobe-style Mesa Laboratory and it supports the work of several hundred scientists who study weather and climate. Rios-Berrios is originally from the US island territory of Puerto Rico, and her talk focused on hurricanes. In particular, she is trying to find out what happens in the atmosphere to cause gentle Caribbean breezes and fluffy white clouds to morph into devastating hurricanes like last year’s Melissa, which devastated parts of Jamaica.

Rios-Berrios’ work (see box below “How to predict a hurricane”) could make it possible to forecast active tropical cyclone periods several weeks in advance – a real boon for anyone living on tropical islands or coasts. Fortified by this promising result, I crossed to the “science crisis” session down the hall just in time for a talk by Zuoyue Wang, a science historian from California State Polytechnic University. He discussed parallels

## Zuoyue Wang discussed parallels between a succession of science budget crises during the Cold War and the current crisis in US science under the Trump administration

between a succession of science budget crises during the Cold War and the current crisis in US science under the Trump administration.

To my surprise, Wang’s first slide featured a photo of NCAR’s iconic Mesa Lab – but not because of the great work being done there by Rios-Berrios and her colleagues. The fact that NCAR studies climate as well as weather means it has fallen foul of MAGA Republicans’ denial of climate change. Late last year, the Trump White House issued a memo specifically targeting the centre, claiming that “NCAR’s activities veer far from strong or useful science”.

As a consequence, Wang told the audience, “NCAR is being dismantled as we speak.” Though some members of the US Congress have pushed back against the administration’s cuts, Wang described the attacks on science as “never-ending”. By the time he finished speaking, all the optimism I’d built up in hearing about Rios-Berrios’ work was blasted from its foundations.

If this is the kind of science the current US regime deems “useless”, I wondered, what on Earth is going to happen to the rest of the work on show at events like the GPS?

**Margaret Harris**

### How to predict a hurricane

NOAA/NESDIS/STAR GOES-19 satellite image

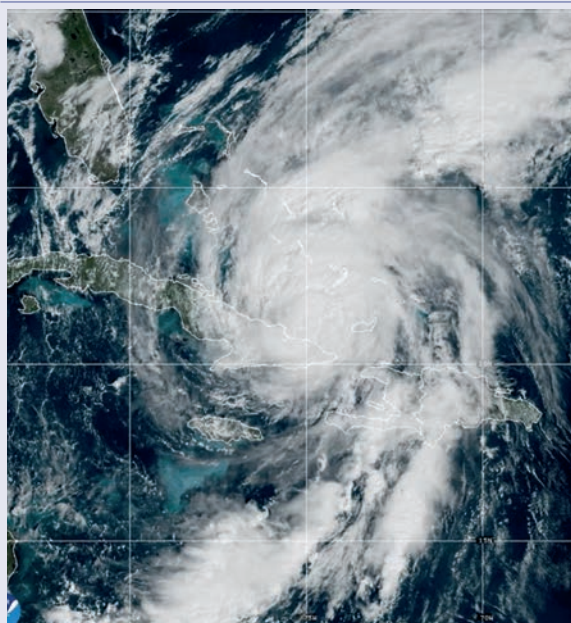

**Weathering the storm?** As Hurricane Melissa approached Jamaica on 28 October 2025, an aircraft equipped with an NCAR-developed system released several probes, or sondes, into the storm. One of these sondes measured a wind gust of more than 400 km/h, the strongest ever recorded by this method.

In previous studies of hurricanes, a specific type of atmospheric wave called a convectively coupled Kelvin wave had emerged as a possible hallmark of incipient tropical cyclones (a generic term for hurricanes and their Pacific Ocean equivalents, typhoons). These waves appear in the region near the equator where northeast and southeast trade winds meet, and they move eastward at around 15–20 m/s, with wavelengths of 7000 km.

As they travel, the Kelvin waves perturb local concentrations of moisture, and their passing heralds a change in the direction of the prevailing winds. The resulting “zonal wind anomalies” are thought to play a role in spawning early-stage tropical cyclones. Observational data support this idea: two days after these waves pass through an area, there’s a noticeable uptick in tropical cyclones.

Speaking at the Global Physics Summit in Denver, Rosimar Rios-Berrios from the National Center for Atmospheric Research (NCAR) described how she investigated this correlation by developing an idealized model that captures the convective dynamics of both Kelvin waves and tropical cyclones. To simplify things, she based her model on an Earth-like “aquaplanet” that lacks land and sea ice, and where temperatures vary only with latitude, and never with longitude or the passage of the seasons.

Despite these simplifications, Rios-Berrios found that this watery model world nevertheless produces hurricane-like swirls of wind and cloud. And after observing the full life cycle of more than 100 simulated tropical cyclones, she concluded that Kelvin waves do, in fact, influence their formation, with a two-day time lag that corresponds well to the data. “These results could help forecast active tropical cyclone periods several weeks in advance,” Rios-Berrios told her audience in Denver.

**Margaret Harris**



Victoria Merriman/IOP Publishing

**Supporting physics**  
Participants at the Global Physics Summit satellite event in Cameroon, April 2026.

**Expanding access**

There were 14 000 delegates at this year’s GPS in Denver, but not everyone around the world has the time, money or visa paperwork to attend in person. That’s why it was great that the APS, along with AIP Publishing and IOP Publishing – which together form the Purpose-led Publishing (PLP) coalition – hosted a network of 23 satellite events at venues in Africa, Asia, South-West Asia and South America to expand participation in this year’s GPS.

PLP’s satellite hubs, which took place both in person and online, were designed to let researchers engage with the summit programme, contribute to discussions and take part in local workshops and presentations. Held in countries ranging from Brazil and Benin to the Philippines and Pakistan, the events hosted livestreamed and recorded content from Denver as well as offering debates, expert-led sessions and opportunities for networking.

I travelled to one GPS satellite event in Cameroon to represent IOP Publishing and the PLP coalition. Held at the University of Dschang, it ran alongside the Central African School on Electronic Structure Methods and Applications. Both were attended by students and senior academics not only from Dschang, but from the wider region, including the Central African Republic, Gabon, Republic of Congo, Democratic Republic of Congo and Chad. Some participants had spent days getting there by bus.

**Students spoke about funding pressures and uncertainty for early-career researchers, and how collaboration across borders helps sustain teaching, curricula development and postgrad training**

As I discovered, the environment in which teaching and study takes place is extremely challenging. Power outages are frequent, Internet access is extremely limited, and much of the university’s infrastructure is basic and ageing. Staff often rely on generators and equipment they have funded themselves to keep teaching and research activities running. Even watching the GPS live-streamed events proved tricky.

What’s more, funding for science is scarce, PhD places are extremely limited, and sustaining research careers in this environment is an ongoing challenge. But despite these constraints, the engagement and commitment of everyone I met was incredible. Throughout the week, questions were thoughtful and wide ranging and discussions often ran over time. In fact, some of the most meaningful conversations happened outside the formal programme.

As part of the week-long programme, I gave presentations on the principles of scholarly publishing, such as writing and submitting papers, choosing journals and understanding peer review. I also discussed research integrity, the responsible use of AI and how researchers can maximize the reach and impact of their work.

There was a clear interest in talking openly about publishing, research practice and career development, both during the sessions and beyond them. Students spoke openly about funding pressures and uncertainty for early-career researchers, while also describing how collaboration across borders helps sustain teaching, curricula development and postgraduate training in neighbouring countries.

What stayed with me most was the warmth and openness of everyone involved. Many participants reflected on how valuable it was to have the opportunity for direct, honest conversations about publishing and research ethics, something they do not often experience face to face. Attending the event in person was a real privilege, offering a rare opportunity to build relationships in support of a truly global scholarly community.

**Victoria Merriman**

ECONOMIST  
ENTERPRISE

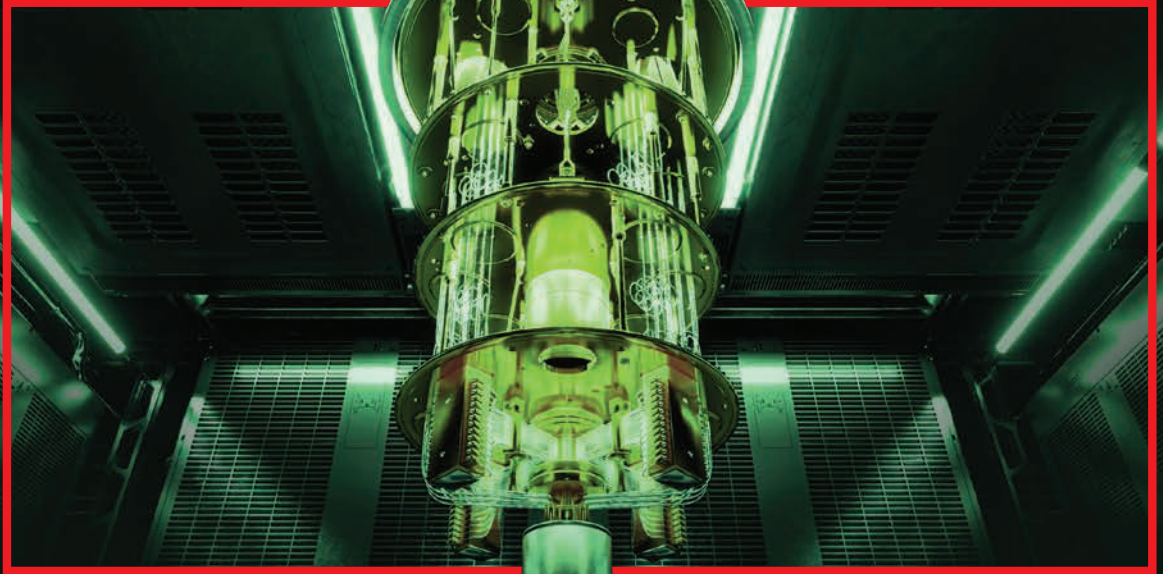

# 5th annual Commercialising Quantum Global

June 16th-17th 2026 · London

More than: 1,100 attendees

120 speakers

40 case studies

## From qubits to profits: AI, advantage and enterprise readiness

What's real, what's next and what's worth watching? Join us in London to sharpen your quantum strategy with conversations and case studies. Hear from global leaders across science, industry and policy who are defining the next phase of quantum adoption.



**Lord William Hague**  
Chancellor  
University of Oxford



**Lord Christopher Holmes**  
Member of the House of Lords,  
UK



**Gillian Bussey**  
Deputy chief science  
officer  
US Space Force



**Aparna Prabhakar**  
Chief strategy and  
sustainability officer  
Schneider Electric



**Marielle van de Pol**  
Senior vice-president, head  
of enterprise architecture  
and technology strategy  
Danske Bank



**Akshay Pore**  
Managing director, data  
modernisation, AI automation  
and strategic architecture  
Bank of America



IOP members: register for your complimentary pass using the QR code [commercialisingquantum.economist.com](https://commercialisingquantum.economist.com)

Lead sponsor



Sapphire sponsors



Gold sponsor



Silver sponsors



Associate sponsors



Exhibitor sponsors

# TC-2 & TC-8

## Multi-Channel Temperature Controllers



SCIENTIFIC  
INSTRUMENTS



**TC-2**

(2) Inputs  
(1) Output (50W or 100W)



**TC-8**

(8) Inputs  
(2) Output (25W/50W or 50W/100W)

### Key Features

- Measurement and control down to 300 mK
- Automatic tuning of excitation current for high accuracy and low self-heating
- Thermocouple options available
- Supports temperature ramp rate setting
- Zone Mode - PID parameters adjustable per zone table for temperature ranges
- Automatic protections: heater short and open detection, setpoint limits are supported

-----  
[sicryo.com](http://sicryo.com) • [sales@sicryo.com](mailto:sales@sicryo.com) • (800) 466-6031

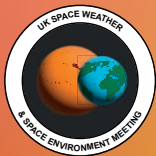

## UK Space Weather and Space Environment Meeting IV: Space as a Global Endeavour

**14-17 September 2026**  
Northumbria University,  
Newcastle upon Tyne, UK

Building on a strong UK foundation, the UK Space Weather & Space Environment Meeting is now in its fourth iteration, continuing to expand its international reach and impact. This established series focuses on space weather and the wider space environment, reflecting the essential role of global collaboration in advancing our understanding of – and resilience to – the dynamic space environment and its effects on both Earth and space-based systems.

**IOP Institute of Physics**

[iop.eventsair.com/ukswse2026](http://iop.eventsair.com/ukswse2026)

The meeting provides a vital platform for engagement across disciplines, bringing together scientists, engineers, forecasters, end-users, and policy makers. By fostering dialogue between these diverse communities, it supports the development of coordinated approaches to space weather research, forecasting, and mitigation.

With a commitment to collaboration across borders, the series aims to strengthen partnerships within the UK and internationally, contributing to a more robust and responsive space weather community. Participants can expect insightful discussions, knowledge exchange, and opportunities to shape the future direction of this rapidly evolving field.

Join us in advancing the science and application of space weather in an increasingly interconnected world.



# Coffee with a splash of physics

iStock/Hispanolistic

It takes more than 150 people to make a cup of coffee, from farmer to barista. But if that final person makes a mistake, your precious coffee is wasted. **Michael Allen** investigates whether physics can help us brew smarter so we don't waste a product that's threatened by climate change

Espresso, flat white, cappuccino, cortado – there are dozens of ways you can get your coffee fix. Every day more than two billion cups of coffee are brewed worldwide, making it one of the most traded products on Earth. In fact, it is the seventh most traded commodity on the planet (after crude oils, natural gas, gold, silver and copper).

Produced mainly in south and central America, south-east Asia and east Africa, coffee sustains the livelihoods of more than 25 million farming households. But its future is increasingly precarious. Coffee plants need the right temperature range, rainfall patterns and altitude to thrive, but climate change is disrupting it all.

This has led to falling yields and rising prices. For example, the price of Arabica beans – the most dominant coffee variety – rose by more than 80% in 2024. In the UK, this led to the price of beans at supermarkets rising 20% and the cost of some instant coffee surging by 40%, while

coffee shop prices were up 30% from 2021 to 2024.

And it's not just that coffee is affected by climate change – the climate is impacted by coffee. It has one of the largest carbon footprints of any plant-based product, mainly due to the clearing of tropical forests, fertilizer and water use, and processing techniques.

So how can those of us making the drinks help with the coffee and climate crisis?

## At-home scientists

Coffee is an unusual drink. Unlike products such as whisky, wine and beer, it is brewed at the point of consumption, whether that's in a café or restaurant, or in a home. "The very last step, which is probably the most complicated, is all done by untrained scientists," says Christopher Hendon, a computational materials chemist and coffee expert at the University of Oregon.

**Michael Allen** is a science writer based in the UK

## 1 Espresso basics

iStock/GerasimovSergey

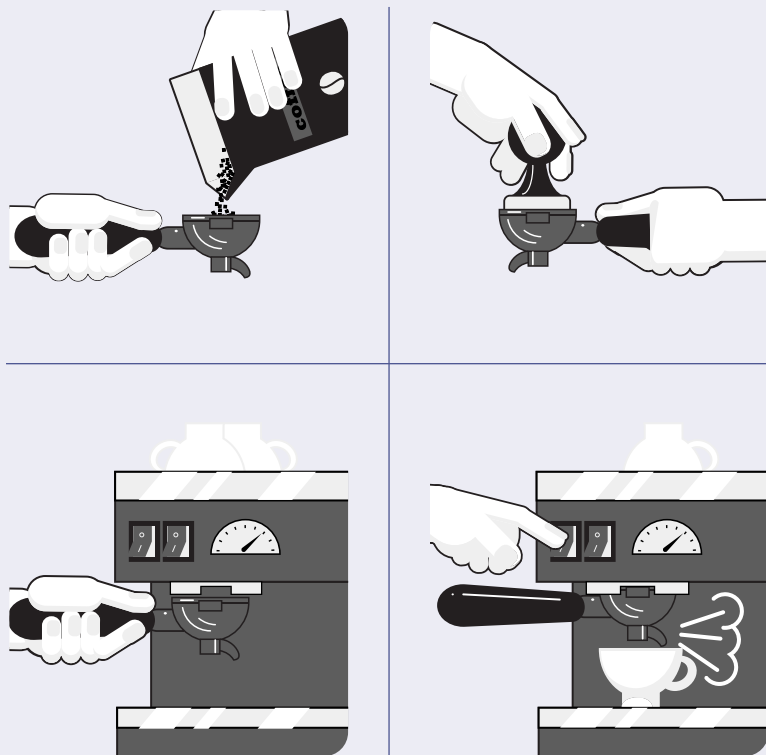

If you've ever had an espresso-based coffee, you'll know that making that base shot of concentrated caffeine is more than just putting some beans in a machine and pressing go. Like with any experiment in a lab, there is a strict process with a range of variables (and a bunch of lingo). Here's a quick and very basic guide to making an espresso with an espresso machine:

1. The coffee beans are ground down into a powder-like substance
2. The ground coffee is then measured out in a "basket" at the end of a "portafilter" (top left)
3. To ensure this coffee is evenly distributed, baristas then lightly tap the basket, and some may manually move it around
4. Next the coffee is pressed down in the basket using a "tamper" to make it tightly and evenly compacted (top right), creating the coffee "puck"
5. Before the portafilter is attached, it's a good idea to purge the machine with water to ensure no contamination from the previous brew
6. Now it's time to actually "pull the shot". The portafilter clicks into place (bottom left) and, if following the historical definition, high-pressure hot water (9–10 bars, 90–96 °C) is pushed through the puck for 20–30 seconds resulting in 25–35 ml of espresso (bottom right)

It is estimated that it takes 155 people to make a cup of coffee – all the way from the farmer who plants the seed in the ground, to the barista who hands you your cup of coffee. "154 people can do their job perfectly," says Dan Pabst, manager of innovations and product development at coffee provider Melitta North America. "But if that last person doesn't pay attention, does something wrong and the coffee doesn't taste right, they've just ruined all that hard work."

This is where physics can help. Beyond longer-term, large-scale solutions such as re-engineering coffee plants or tackling climate change, physics can actually tell us a lot right now about what happens during the seconds and minutes it takes to brew a cup of coffee. It is a sur-

prisingly complex process and by understanding it, we can improve the quality of the drink and even reduce the amount of coffee needed, cutting waste and helping the environment.

### Under pressure

Let's start with the espresso – those concentrated coffee "shots" you get in tiny cups that also form the base for your latte, americano or cappuccino (and many more).

The Specialty Coffee Association (SCA) has historically defined an espresso as a 25–35 ml beverage prepared from 7–9 g of coffee through which water heated to 90–96 °C is forced at 9–10 bars of pressure for 20–30 seconds. "While brewing, the flow of espresso will appear to have the viscosity of warm honey and the resulting beverage will exhibit a thick, dark golden crema," states the SCA. This can be achieved using an espresso machine (figure 1), or with smaller contraptions at much lower pressures such as a moka pot or AeroPress.

In 2017 the SCA and the Barista Guild of America surveyed baristas around the world to see how they were preparing their cups of espresso and if they were following the historical definition. Turns out that the average barista brews an espresso with 18–20 g of coffee in 25–30 seconds using water heated to 93 °C at 9 bars of pressure. This produces an average shot of 36.5 g.

Go online and you'll also find all sorts of claims about how to produce a perfect coffee. "From a scientific point of view, this advice is often given with no substantial evidence," says Maciej Lisicki, a physicist at the University of Warsaw. Keen to understand the real science behind a good espresso, Lisicki and his colleagues looked at the complexity of flow in coffee brewing (arXiv:2512.21528).

One frequent claim by coffee experts is that the optimal brewing pressure for an espresso is around 6–9 bars, and that pushing it higher yields diminishing returns. To find out why, Lisicki's team rigged a café-grade espresso machine with a pressure sensor at the pump outlet, and a precision scale under the coffee cup so they could calculate flow rate. They prepared the puck using a high-spec coffee grinder and automatic tamper to ensure consistency, and then brewed shots of espresso at pressures ranging from 1 to 12 bars. "We strive for our espresso to be the same every time," says Lisicki. To visualize their structure, the researchers also took X-ray micro-computed tomography (micro-CT) scans of the coffee pucks before and after brewing.

Fluid flowing through a porous medium, such as sand, glass beads or packed soil, usually follows Darcy's law, with flow rate increasing linearly with the pressure of the liquid. But the researchers found that this was only true for coffee up to around 5 bars. Above that, the flow rate flattened and then fell as pressure increased.

The team observed that as the coffee is brewed, the puck starts compacting under mechanical load, causing its pores to collapse and its permeability to decrease faster than the rising pressure can increase the flow. "The dynamics of espresso brewing is governed by this poroelastic effect," Lisicki says. "There is an interplay between the porosity and the elasticity of the coffee matrix."

Ultimately, the work confirmed what the coffee experts had observed. There is no point pushing the pressure beyond about 8 or 9 bars as the flow rate has already peaked.

## 2 Infiltrating the puck

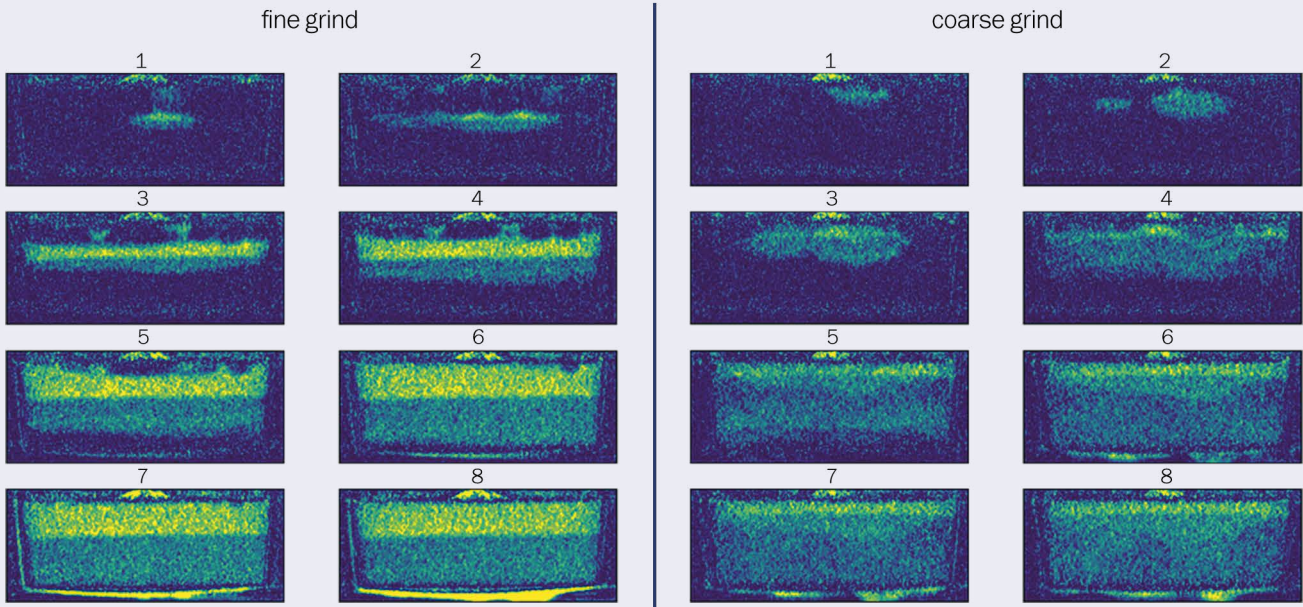

When water is initially pushed through a dry espresso puck, it can take up to one-third of the brewing time to permeate the entire bed of ground coffee. But according to mathematician Ann Smith and colleagues, this process remains relatively neglected by mathematical models of coffee extraction.

“Understanding the infiltration process gives insights into the extraction rate across the coffee bed,” says Smith, who is based at the University of Huddersfield in the UK. “Over-extracting coffee results in bitter taste while under-extraction leads to both weak brews and wasted resources.”

To study infiltration dynamics through both a coarse and a fine grind, the researchers set up an espresso machine at the centre of

a rotating X-ray tomography system, which allowed them to build 3D reconstructions of the pucks (*Physics of Fluids* **37** 013383). They found that water travels more slowly but more uniformly through a fine grind (left) than a coarse grind (right), which can be seen in the above cross sections of the coffee pucks showing the absorption data for the first 8 seconds of brewing time. The researchers also built a flow model of the water permeation, which showed a good fit to the experimental data.

The team plans to build on the model by looking at other infiltration influences, such as brewing temperature and pores in the puck. “We have pioneered a new technique for experimentally validating coffee models, opening up several interesting avenues of future research,” the team says.

### The coffee in your coffee

Next, to explore how coffee dissolves over time, the team separated an espresso into different vials every five seconds as it brewed. An optical refractometer then measured the total dissolved solids in each vial. This, says Lisicki, tells you “how much coffee is in your actual coffee”.

The work showed that the first few drops of coffee that fall into your cup are very concentrated, but there aren’t many of them because flow rate is initially low. The flow rate then increases, but the amount of dissolved solids falls. This creates a sweet spot at around 15 to 20 seconds where the dissolved solids entering the cup peak, due to the balance between the increasing flow and decreasing solids.

Again, this tallies with expert opinion. “What we see is that most of the substance, the solubles, go into your cup within the first 30 to 35 seconds,” Lisicki says.

After talking to a friend who works as a barista, Lisicki and his colleagues also explored an annoying problem in coffee brewing known as channelling. This happens when the water finds a path of least resistance in the puck and forms a “channel” through the coffee grains. When they brewed coffees with artificially induced channels in the puck, the researchers found that the flow rate was as expected but the total amount of dissolved solids that were extracted was very low. Essentially, the water

doesn’t permeate the rest of the puck, so you can’t extract all its coffee.

In fact, the team found that the more careless you are about preparing your coffee puck, the higher the chances of channelling. To mitigate this, you should stir the coffee grounds to make the puck as homogenous as possible and tamp it evenly. “You don’t need to tamp it very strongly, but tamping is important because if you don’t tamp then it’s easier for the water under high pressure to find a preferential flow path,” Lisicki says.

### More from less

But even before you tamp your puck, how you prepare your coffee grains affects your drink’s quality. This is where grind size matters (figure 2). Back in 2020 Hendon and an international team were funded by the Coffee Science Foundation – the research arm of the SCA – to study ways to make highly reproducible espresso (*Matter* **2** 631).

The group started by looking at what happens in the coffee grinder. You might think that a more finely ground coffee will maximize the surface area exposed to water, thereby maximizing extraction. Hendon and his colleagues discovered, however, that this was not the case.

As grind size decreases, from coarse to fine, the amount of coffee that gets extracted initially rises but then peaks and falls. If the grind is too fine, the coffee bed clogs so

**3 Caffeinated static**

CC BY NC Matter 7 266

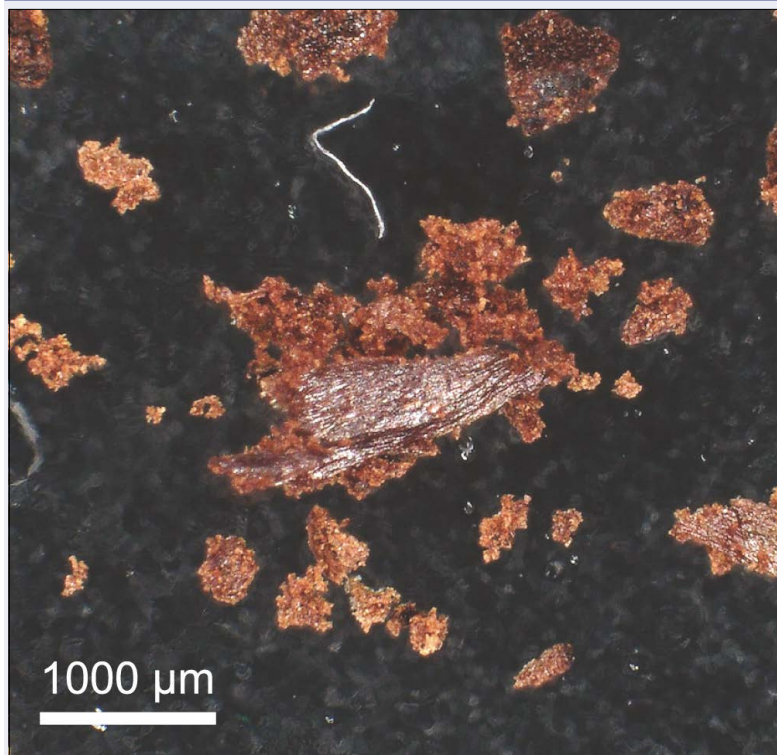

A team of scientists including coffee expert Christopher Hendon found that pores in a coffee puck clog if the coffee is ground too finely. After teaming up with volcanologist Joshua Méndez Harper, he discovered this was due to the grinding process introducing static charge, which caused the coffee to form aggregates, like those shown, that blocked water flow.

that water can no longer percolate uniformly through it. Much like with channelling, some areas are over-extracted, while others are barely touched

“If you find the tipping point, you’ll realize the amount that you’re extracting on average [with a coarser grain] is actually much higher than if you ground finer,” Hendon explains. This means you also need less coffee to make an espresso of the same concentration.

The bottom line of the team’s experiments and mathematical modelling is that to get the most reproducible shots just use less coffee and grind it more coarsely.

Pabst echoes that advice: “My recommendation for people at home, without knowing anything they are doing, 90% chance that if you use less coffee and grind a little coarser [your coffee] will actually taste better.”

Hendon and his team trialled their “waste reduction protocol” at a small café in Eugene, Oregon in the US. By grinding more coarsely and reducing the dry coffee mass by 25%, from 20 g to 15 g, the business increased its revenue by more than \$3000 over a year, without sacrificing drink strength or flavour.

Based on estimated US espresso consumption figures from the time, Hendon and his colleagues suggested that if their findings were implemented across the entire US, it could save the country about a billion dollars per year.

**Volcanic coffee**

It was not until Hendon teamed up with a volcanologist that he figured out why finer grinds clog the coffee bed

and reduce extraction. Joshua Méndez Harper at Portland State University studies electrification in volcanic eruptions, where magma fragments charge up as they grind together in the plume, generating lightning. Coffee grinding, it turns out, creates a similar phenomenon (*Matter* 7 266, *iScience* 27 110639).

Together, Hendon and Harper found that friction between beans and the fracturing of beans during grinding generates static electricity. By passing coffee through a grinder a second time at a coarse setting, which removes fracturing from the process, the researchers discovered that most of the static charge arises from fracturing rather than friction.

According to Hendon, the more times you fragment your coffee, the more static electricity you generate. “You’re making lots of small particles when you grind finer, but they clump together to form an aggregate [because of static], which is effectively impermeable to water,” he adds (figure 3).

The solution, the researchers found, is to squirt a little bit of water on the beans before you grind them. “That totally suppresses the static accumulation,” Hendon says. Wetting whole beans with less than 0.05 ml of water per gram of coffee – or about 0.5 ml for an average espresso shot – resulted in a marked shift in particle size distribution by preventing clump formation.

But again, the coffee experts got here first. In the coffee industry, this is known as the Ross droplet technique and was anecdotally thought to reduce static charge, even if the physics wasn’t well understood. Pabst says that a lot of the recent findings “are not necessarily newer ideas, they are validating what we have taught in the industry for many years”. But he describes it as an exciting time, with science providing deep insight into industry knowledge.

Moisture content of the beans is another key variable, Hendon’s team found, with drier, darker roasts charging most strongly and therefore benefiting most from pre-wetting. The researchers also found that the right amount of water results in near-zero grounds being retained by the coffee grinder, again due to the reduced static charge.

They note that their findings have implications for waste reduction and drink quality. Hendon says that adding water during grinding allows you to reduce coffee mass by about 25%, while maintaining espresso concentration.

**Pour-over science**

Coffee is not just espresso.

Among the myriad of coffee-making techniques available, pour-over coffee is increasingly popular with enthusiasts due to its reputation for being better able to extract the unique characteristics of different coffee beans. A popular set-up uses a conical filter or “dripper” containing a filter paper, and the process is simple – you put coffee grounds in the filter, pour in hot water, and let the coffee drip out into a cup. There is a wealth of variables – such as grain size, water temperature and water speed – that allows whoever is holding the kettle to experiment and vary the process.

However, Arnold Mathijssen, a physicist at the University of Pennsylvania, has been studying exactly how they should be pouring that kettle (*Physics of Fluids* 37 043332).

As with an espresso, the challenge is to bring the water into uniform contact with every particle in the coffee bed.

## 4 Avalanche dynamics

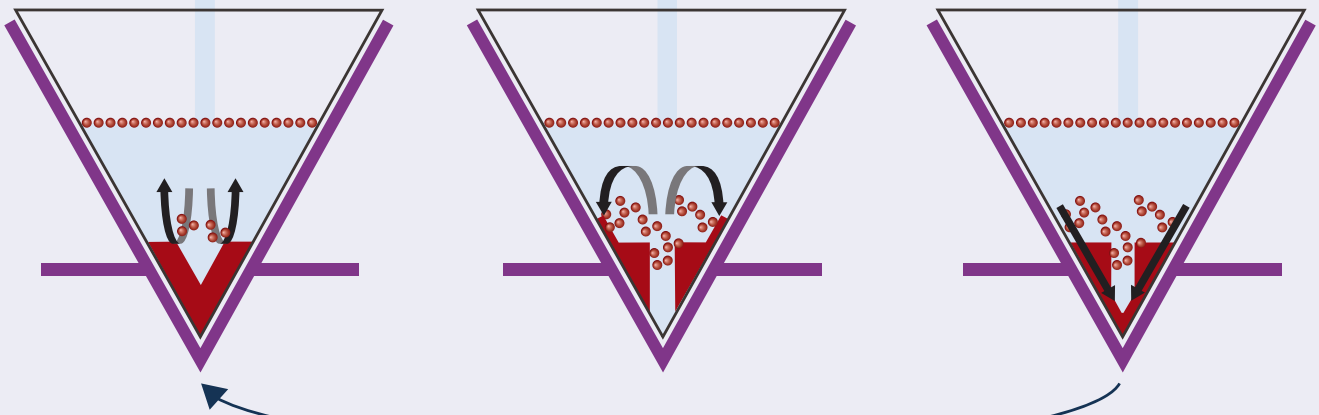

The stages of coffee grinds moving in a pour-over coffee set-up. First, a water jet starts to erode the coffee bed, causing the granules to become suspended and mixed into the water (left). These then accrete outwards towards the edge of the coffee bed (centre). The movement of granules from the bottom to the top edge causes the bed to collapse inwards (right), and the entire process repeats while the water jet continues.

Reused from *Phys. Fluids* **37** 043332. By permission of AIP Publishing

If the stream is too slow, for instance, it might run to the edges of the cone, flow through the filter paper and drain away without touching the grains in the centre.

To investigate how pouring technique affects this, Mathijssen and colleagues used a transparent glass cone similar in shape to a popular pour-over filter, and ultrathin filter paper. They then filled it with silica gel particles as a transparent model for coffee grains, and illuminated the set-up with a laser sheet while filming it with a high-speed camera.

The experiment revealed the importance of pour height for a static kettle. Pour from close range and the slow stream fails to effectively disturb the coffee bed. Lift the kettle to around 20 cm above the filter and something different happens. “We found that as you increase the height of the kettle this kind of avalanche dynamic emerges,” describes Mathijssen.

The increased energy in the stream enables it to dig deep into the coffee bed, suspending the particles and creating a hole in the middle. Particles around the side then slide into the centre and are themselves suspended, establishing a recirculating vortex (figure 4).

“Every single particle in that cone is moving up and down through this vortex, so you get very nice and even extraction,” explains Mathijssen. “All of the particles see the water for an equal amount of time.”

But go too high, above about 30 cm, and surface tension breaks the stream into droplets – a process known as the Rayleigh–Plateau instability. The drops fail to dig deep into the bed, so the vortex does not form and coffee extraction falls. There is a sweet spot at a height of around 15–20 cm, Mathijssen says.

When the researchers switched back to coffee, they found that higher pours did indeed create stronger coffees with more total dissolved solids.

### One cup at a time

These studies highlight a common theme. Decent coffee extraction is about creating uniform fluid contact with a porous medium that tends to be heterogeneous. And if it goes wrong, it is probably due to some failure of



istock/ArtRachen01

**Drip drip drop** Pour-over coffee allows the brewer to experiment with variables such as water temperature and grind size.

that uniformity.

As climate change squeezes yields and pushes prices higher, the coffee industry faces growing pressure to do more with less. Physics cannot protect vulnerable growing regions from drought and rising temperatures, but its insights can ensure that coffee is not wasted in the final seconds or minutes by a poorly prepared puck, a clumped grind or a lazy kettle lift.

“The best thing we can do,” says Hendon, “to be good custodians of any agricultural product is figure out how to use less of it so that more people can enjoy it.” ■

● Why not try our crossword inspired by this feature: “Caffeine kick: can you solve our crossword on coffee physics?” at [physicsworld.com/a/caffeine-kick-can-you-solve-our-crossword-on-coffee-physics](https://physicsworld.com/a/caffeine-kick-can-you-solve-our-crossword-on-coffee-physics)

## Building up the quantum workforce

Frédéric Sarazin, director of quantum at the Colorado School of Mines in the US, talks to **Tushna Commissariat** about the industry demands and workforce needs of the quantum sector, and why he helped to establish the first quantum systems engineering bachelor's degree in the US

Quantum technologies are undoubtedly going to have a large impact on our world, potentially revolutionizing everything from healthcare and the environment, boosting the economy and helping with large-scale optimization challenges. But for them to deliver on these many promises, it will be vital for many countries to train and build a quantum-ready workforce.

There are four pillars to the quantum sector – quantum computing; quantum simulation; quantum communication; and quantum sensing and metrology. But in each case there is a lack of trained individuals who can take on jobs across the board. Indeed, statistics in both the UK and the US suggest there is only one qualified worker for every three quantum jobs. With governments continuing to invest lots of money into national quantum programmes; a growing number of new quantum start-ups being launched; and ever more multinational firms zoning in on quantum, the shortage of those with the right skills to work across the sector is expanding.

The Colorado School of Mines in the US is now trying to remedy this situation by launching the country's first bachelor-level quantum systems engineering degree programme, due to start this autumn. An undergraduate degree specializing in quantum and systems engineering might, at first glance, seem odd. But 2021–2023 data from the Chicago Quantum Exchange show that 55% of quantum tech jobs only require a BSc or two-year associate degree. For instance, roles that ask for just a BSc include systems assembly and maintenance, measurement engineers, technical sales and marketing.



Photo by Tim Meyer. © 2024 Colorado School of Mines

**Training ground** PhD students working with associate professor of physics Meenakshi Singh (left) on the dilution refrigerator in one of the quantum labs on the Colorado School of Mines campus. The quantum labs will also be used by students on the new bachelor's degree in quantum systems engineering at Mines.

“Industry demand especially values engineers with a systems-level understanding of quantum devices, and there is also a need for quantum technicians who can build and maintain quantum hardware,” says Frédéric Sarazin, director of the quantum programme at Colorado School of Mines. As the first standalone bachelor's degree in quantum systems engineering in the US, the programme is designed specifically to supply industry-ready graduates.

The main focus for Sarazin and colleagues was to bring into the programme key aspects of systems engineering – which involves understanding and overseeing all aspects of a complex system, from its inception through to practical production, and even managing the final product. The goal: to help companies get their products and technologies out of the lab and into the marketplace. Rather than focusing on isolated components, systems engineers are trained to understand how complex technologies behave as integrated entities.

“A quantum computer, for example, is more than just its qubits,” says Sarazin. “It's cryogenics, optics, electronics, control software, signal processing and the user

interface, all interacting with each other.” Companies are keen to hire people who can understand and help develop their quantum product as an end-to-end system, bridging the gap between the physics and engineering aspects, as well as making sure the end product is robust, scalable and manufacturable.

The physics may be what Sarazin calls the “secret sauce” – but turning it into a device that is reliable, manufacturable and maintainable is an engineering problem “with a quantum flavour to it”. “What companies want is people who understand the product as a system, from beginning to end,” Sarazin explains.

### Quantum hotspot

Colorado, in America's mid-west, is a quantum innovation hotspot, with quantum companies employing more than 3000 people across the state. To develop the new programme, Sarazin and colleagues carried out an extensive consultation process with companies, institutions and organizations that all look to hire quantum engineers, to get a clear idea of the skills that students should have at the end of their course. They also collaborated with Elevate Quantum – a

## True requirements

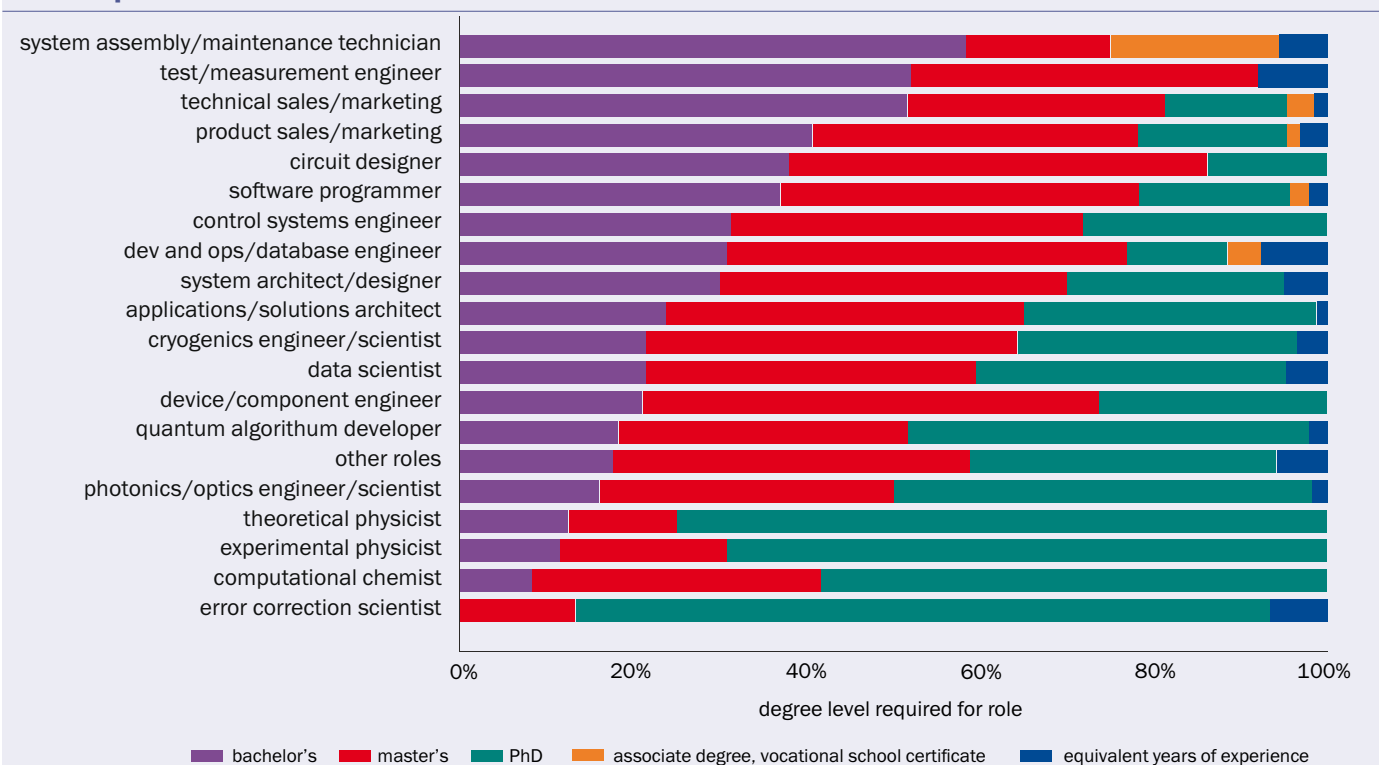

Distribution of degrees needed for different job roles in the quantum industry.

CC BY 4.0 / IEEE Transactions on Education 65 592

consortium of 120 organizations advancing quantum workforce development and commercialization in Colorado, New Mexico and Wyoming – to design an interdisciplinary course that will integrate physics, electrical and mechanical engineering, computer science and engineering design.

While the students will learn plenty of foundational quantum physics, they won't cover the full curriculum of a traditional physics degree. "You'd be talking about a six-year degree if we covered everything," says Sarazin. Certain advanced topics, such as quantum error correction, remain overwhelmingly in the domain of PhD-level jobs and so are deliberately excluded.

A key feature of this degree will be hands-on practical engineering experience in the lab. Plans are under way to build a dedicated quantum device laboratory for the students, allowing companies to bring in their tech and partner with the on-campus facilities. "The lab is meant to be a signature experience," says Sarazin. "It's where students start interacting with industry in a meaningful way."

That connection is reinforced through internships and a year-long design project in the final year, with project topics supplied

directly by quantum companies. "The junior-to-senior year is when internships really matter," explains Sarazin. "That's often what leads directly to a job."

### Future prospects

Although the programme is firmly industry-focused and aims to get graduates straight into the job market, students can progress to the Colorado School of Mines' existing master's programme in quantum engineering, launched in 2020. "At the bachelor's level, you're building breadth,"

**The lab is meant to be a signature experience. It's where students start interacting with industry in a meaningful way**

says Sarazin. "If students want to specialize further, they absolutely can."

Many of the skills that the students will develop – from electronics and embedded systems to control software and algorithms – are highly transferable too. "Looking beyond the quantum sector, our systems engineering students will have acquired a set of skills that is highly applicable in other industries," says Sarazin.

The first cohort will likely be around 15–20 students this year. Looking ahead, Sarazin has a clear benchmark for success: "a near-100% placement in industry at the end of the degree – that's what we're aiming for".

Beyond that, success will mean continuously refining the programme in response to industry feedback. "This isn't static," Sarazin says. "If companies tell us something needs adjusting, we want to respond." For students still hesitant to take the leap into a specialized BSc or the quantum sector, Sarazin's message is clear: quantum careers are here to stay and the direct path into the industry is starting earlier than ever before.

**Tushna Commissariat** is features editor of *Physics World*

# Quantum science in the heart of Dublin

Trinity College Dublin is at the centre of a burgeoning quantum ecosystem in Ireland, and students on Trinity's MSc Quantum Science and Technology are right in the middle of it all, not only reaping the benefits but also taking an active part in helping Ireland's quantum community flourish

The impact of quantum science and technology is going to be profound, with quantum computing in particular – but also quantum sensing, simulation and communication – set to be a major driver of economic growth and sustainable development in countries around the globe.

Ireland is no exception. It is already home to some of the world's largest technology companies, many of which are heavily investing in quantum technologies. Moreover, the country's quantum research and innovation community demonstrates a significant level of expertise in fundamental quantum science and quantum technology.

But to ensure Ireland is not only a user of quantum technologies but an active contributor to its development long into the future requires both strong partnerships with industry and public research bodies across borders, and the consistent production of people with the talent and skill to push quantum science forward.

## Transferable skills across academia and industry

Founded in 1592, Ireland's oldest university Trinity College Dublin hosts a future-focused MSc Quantum Science and Technology programme that fits this remit perfectly. The one-year master's course is the ideal stepping stone into a career in quantum research, whether students want to advance fundamental knowledge in academia or develop the next world-leading quantum technology in industry.

"Unlike other fields, for many of the exciting positions in industry, the skills are very similar to what would be required of a PhD student," explains quantum information theory expert Professor Felix Binder, who directs the course. "It's a level of scientific rigour, it's having a broad knowledge base and coding skills, it's being confident to independently work on a project – these are what we focus on."

This is why the course very much leans into helping students develop the fundamentals. Topics such as quantum computation, quantum information theory and open quantum systems are covered in



Matt Boyd/Mahoo

Graduate students at Trinity College Dublin.

depth. This provides the foundation for exploring more advanced and specialized topics, like quantum materials or tensor network theory.

The combination of fundamentals and highly specialized knowledge is designed to

equip students with skills that are relevant for the long term, says Binder. Though he acknowledges that now is an exciting time when many quantum technologies are maturing and being commercialized, the course generally looks beyond the latest fads.



Gary Ashe/SHARPIX

Microsoft Ireland scholarship awardees 2023/24 Srishti Nautiyal, Grainne Eager and Nana Werther.

“If students are choosing quantum as their profession, realistically they’re looking at a potential 40-year career,” he says. “As this is their last part of formal lecture-based education, we want to be sure that we set them in good stead for at least many years, and not just the immediate future.”

### Career insights

In addition to preparing students with the knowledge they will need, the course also exposes students to people working at the cutting-edge of the subject, providing them with an understanding of the types of careers available and contacts to build their network and take the first steps towards their chosen quantum profession.

For instance, world-leading academic and industry experts deliver a range of short mini-modules and specialist lectures. Some of these experts come from companies involved in the Trinity Quantum Alliance. “The Trinity Quantum Alliance is a unique space on campus where fundamental quantum science and research meets real-world applications,” says the Alliance’s Director Professor John Goold. “Here, multinational companies, SMEs and start-ups come together to work on projects with Trinity academics.”

The founding industry partners are Microsoft, IBM, Moody’s, Horizon Quantum Computing and Algorithmiq. Each partner shares research and regularly presents talks to faculty and students, and most have a presence on or near the Trinity campus. This arrangement offers students direct access to the people shaping the quantum revolution, as well as potential internship opportunities.



Matt Boyd/Mahoo

**MSc students in Dublin city centre** Trinity College campus, in close proximity to many of the world’s largest tech companies.

Further experts who have given guest lectures and shared their experiences are alumni. Several are completing PhDs at various universities dotted across the world, from the EU to the US and Australia. Many have gone on to become full-time researchers and even team leads in quantum companies, including Quandela, Horizon, Algorithmiq and EleQtron, as well as companies traditionally not associated with quantum technology, such as MasterCard. Others have taken positions at government labs across European countries, including a Max Planck Institute in Germany and a national research centre in the UK.

Although this alumni network may be relatively small – with the course having only been running for five years and graduating 60 students – it is extremely useful for the current cohort, showcasing the different paths potentially available to them and providing contacts who can offer support and advice on how to enter and thrive in those careers.

### A quantum future for the Emerald Isle

Looking forward, Binder envisions even closer integration of the MSc degree and doctoral training into the European quantum ecosystem. This will be enabled through a new EU-wide training network: the European Quantum Academy. Trinity is one of the lead institutions of this new training academy, which was launched in May 2026. Composed of more than 70 partner institutions from across Europe, it will open new opportunities to students in Ireland in terms of industry interaction, inter-

national exchange and advanced training beyond the degree’s core modules.

In addition, there are ongoing plans for further research investment in Ireland, bringing together the different schools within Trinity, and other universities and industry players to work more closely together.

The result of these efforts should be a thriving quantum ecosystem that takes advantage of Ireland’s unique position within the EU and close ties with the US and UK to provide ever more new and varied opportunities in quantum science and technology, as Binder succinctly summarizes: “The field is young and growing – Ireland is a very exciting space for quantum right now”.

- Applications for Trinity’s MSc Quantum Science and Technology are now open for the next academic year. Find out more and apply: [www.tcd.ie/physics/quantumtech/](http://www.tcd.ie/physics/quantumtech/).



**Trinity College Dublin**  
Coláiste na Tríonóide, Baile Átha Cliath  
The University of Dublin

[www.tcd.ie](http://www.tcd.ie)

This article was written by *Physics World* on behalf of Trinity College Dublin. Trinity College Dublin retains copyright on this article. Read more on [physicsworld.com](http://physicsworld.com).



**Professor Felix Binder** Course Director of Quantum Science and Technology MSc, Trinity College Dublin.

**Ask me anything: Ian Griffiths**

Following a career in academia specializing in electron microscopy, Ian Griffiths is now a sales executive at microscope and spectrometer provider JEOL UK

Griffiths studied physics at the University of Bristol in the UK, followed by a PhD in transmission electron microscopy (TEM). He remained at Bristol to do an EU-funded postdoc focusing on 3D gallium nitride LEDs, collaborating with academic and industrial partners in Germany, Spain and Poland. He also worked with the University of Oxford and the University of Southampton on an aberration-corrected scanning transmission electron microscope (STEM).

Following a brief period at the South West Nuclear Hub, Griffiths moved back to Oxford as a support scientist in the David Cockayne Centre for Electron Microscopy, where he managed and trained users on the high-end TEM, and supported electron microscopy research in the Department of Materials. In 2023 Griffiths joined microscope and spectrometer provider JEOL UK as a sales executive, supporting the electron microscope business across the south of England.

**What skills do you use every day in your job?**

Working in a sales role for a multinational company specializing in high-end microscopy equipment often involves collaborating with a wide range of users and customers. Communication and listening are key to ensuring the correct instrument is configured and offered to a customer.

Having been in academia specializing in physics and materials analysis, it's easy to see electron microscopy as a technique for studying traditional metallic or semiconductor samples. In my current role, however, I interact with a whole spectrum of samples, from geological to future battery anodes to cryogenically cooled biological materials. It is important to be able to

**While changing jobs is a daunting task, it has always been worthwhile**



Ian Griffiths

adapt my perception of the technology and also see the similarities between the techniques.

Above all, the main skill I use every day is to be approachable and understanding. The nature of the instruments I offer to customers means they are large value items that will form the basis of their work or research for years to come, and they have often put in a personal commitment to the project and are invested in finding the best solution to their problem.

**What do you like best and least about your job?**

The best aspect of my job is visiting a user to see their new instrument installed at their facility. It's the culmination of a long process – from initial discussions, to visits and demonstrations, to ordering – and the excitement from the customer as they talk about future work they'll be doing is great to see. Being part of their journey and helping them achieve it is a huge positive for me.

Another great part of my job is going to conferences and exhibitions to meet users and hear about the latest research. I'm lucky enough to sit on the organizing committee for the Royal Microscopical Society's annual UK and Ireland electron microscopy meeting. The event aims to not only present the latest community updates, but also highlight the work of research technical professionals and facility staff in academia to

give them greater recognition for the work they do in supporting students and researchers.

One of the parts I like least is discussing projects with users who are constrained with budgets and funding, and hearing about university departments that are sadly struggling for funds and being forced to reduce staff levels. Central facilities – both electron microscopy and other analytical techniques – are often key to the research output of a department but are also hard to maintain without effective central support.

**What do you know today, that you wish you knew when you were starting out in your career?**

I wish I'd known earlier in my career that the most important aspect of a role is to enjoy it. If you find yourself no longer being challenged, look for something new to motivate you. I've enjoyed the different challenges and roles I've done since starting my physics degree, and while changing jobs is a daunting task, it has always been worthwhile.

On another note, I think I underestimated the role and progress that technology and AI would have in everyday aspects of our jobs. These will continue to change and progress, and it's a good idea to be up to date on the latest innovations in your area.

The place for physicists and engineers to find jobs, studentships, courses, calls for proposals and announcements



## Pioneering Superconducting Quantum Computing

Rigetti is a pioneer in full-stack quantum computing. Our quantum computers are available over the cloud via Rigetti Quantum Cloud Services (QCS®), Amazon Braket, and Microsoft Azure.

Rigetti sells on-premises quantum computers, ranging from our 9-qubit Novera™ QPU to full-scale 24 and 84-qubit quantum computers.

Rigetti designs and manufacture our chips in house at Fab-1, the industry's first dedicated and integrated quantum foundry.

### Connect with us!

- ✉ [info@rigetti.com](mailto:info@rigetti.com)
- [in](#) /rigetti-computing/
- [@rigetticomputing](#)
- [@rigetti](#)



Copyright Rigetti Computing 2025

### Rigetti at a Glance

**2013**

Founded

**140+**

Employees

**243**

Patents Issued  
and Pending

### Discover



Careers at Rigetti



Entanglement  
Across Separate  
Dies

**RGTI**

Nasdaq Listed

**17**

Deployed Systems

**70K**

Combined sq. ft.  
of Facilities



Novera QPU  
Product Brochure



Alternating-Bias  
Assisted Annealing



# Quantum is now

## Join us to pioneer its future



### Together, we can make scalable quantum computing a reality

At IonQ we're on a mission to build the world's most powerful quantum computers, capable of redefining how we solve some of today's most pressing problems.

We were founded on the premise that, in order to unlock powerful quantum computing, we needed to combine scale with ultra-high performance. So we flipped the traditional way of building trapped-ion quantum computers on its head.

Instead of relying on lasers to manipulate our qubits, we developed a novel technology called 'Electronic Qubit Control'. This fundamental innovation allows us to trap and control our qubits through electronics integrated directly onto a silicon chip.

Through this approach, we are able to produce our systems via the standard semiconductor industry while also achieving record-breaking performance – **including 99.99% two-qubit gate fidelity.**

We're looking for ambitious individuals excited by the opportunity to join us as we rewrite the rulebook and pioneer the future of quantum computing.

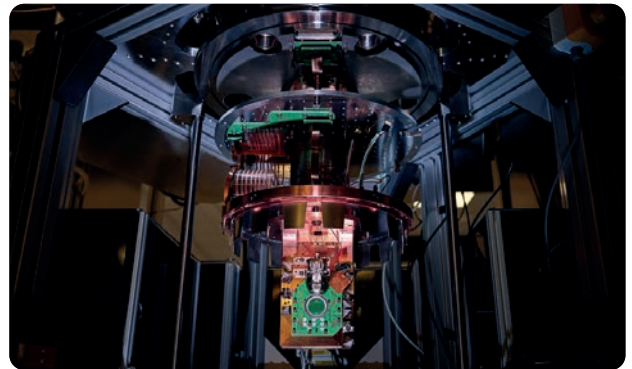

Our teams are made up of a diverse set of talent across departments like physics, engineering, software, architecture, and go-to-market. Common roles include:

- **Quantum Scientists**
- **Quantum System Scientists**
- **Software Engineers**
- **Mechanical Engineers**

**Ready to make history? Join our team today**

Check out all available opportunities on our website at [www.oxionics.com/careers](http://www.oxionics.com/careers)

# Join the Quantum Community in Bavaria

Revolutionize quantum science and technology within a broad, collaborative, and rapidly developing research community. Our close network of institutions and research organizations offers educational and research opportunities for scientists from various fields at all career stages.

Join IMPRS-QST!



International Max Planck Research  
School for Quantum Science  
and Technology (IMPRS-QST)

- **IMPRS-QST** is a joint graduate program uniting the Max Planck Institute of Quantum Optics, Ludwig Maximilian University of Munich, and the Technical University of Munich.

IMPRS-QST serves as a platform for early-career quantum researchers, fostering collaboration, scientific exchange both in Germany and internationally, and comprehensive transferable skills development. In partnership with MCQST, IMPRS-QST offers several highly competitive doctoral fellowships annually, supporting exceptional young scientists as they pursue their PhDs within leading partner research groups..

Find more at [imprs-quantum.mpg.de/](https://imprs-quantum.mpg.de/)

- **MCQST** is a Cluster of Excellence funded by the German Research Foundation (DFG, Deutsche Forschungsgemeinschaft). More than 500 scientists from various disciplines are working on an ambitious research program that covers all areas of quantum science and technology from basic research to applications.

MCQST encourages interdisciplinary collaborations and offers support programs on all career levels ranging from bachelor's students up to independent researchers. With a multitude of different events and outreach formats, MCQST is a driving force when it comes to community building.

Find more at [mcqst.de/](https://mcqst.de/)

Check jobs at MCQST!



Munich Center for Quantum  
Science and Technology (MCQST)

- **MQV** is an initiative supported by the Bavarian state government, uniting quantum activities in Bavaria under one umbrella. Its vision is to create an ecosystem for quantum technologies that combines research, technology development, and education in academia with industry.

MQV focuses on developing competitive quantum computers and aims to fabricate systems with up to 1000 qubits within 5 to 10 years and develop fault-tolerant quantum computers in the long term. MQV provides annual doctoral scholarships to talented physicists, computer scientists, and engineers to do their PhD in quantum-related fields at any Bavarian university.

Find more at [munich-quantum-valley.de/](https://munich-quantum-valley.de/)

Munich Quantum Valley (MQV)



Check jobs at MQV!

Shape the future with us in the Bavarian Quantum Community!

# Are you ready to tackle quantum's biggest challenge?

river  
lane

Collaborate with our team of world-leading scientists and engineers to achieve something that has never been done before: build an integrated platform for real-time quantum error correction.

## Riverlane is the world leader in Quantum Error Correction (QEC)

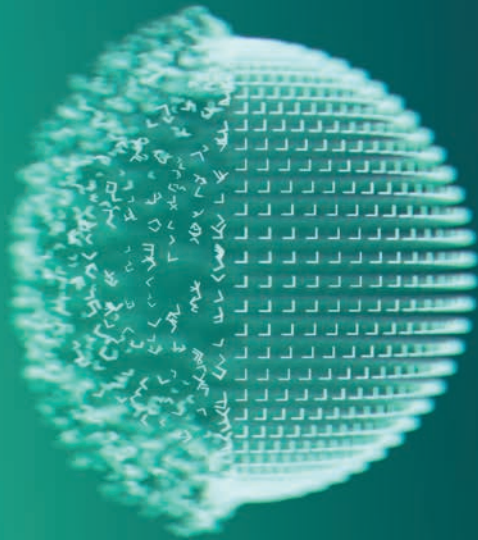

### Areas of focus

Our teams require a range of talent, from entry level interns and graduates, to highly experienced team members. Typical roles include:

- Quantum Scientists and Researchers
- Software Engineers (including Embedded, System Software & Compiler)
- Hardware Engineers (FPGA, ASIC, Verification)
- Project & Programme Managers
- Product Management

Today's quantum computers are overwhelmed by system errors, making it impossible to unlock their full potential. To truly realise the transformative power of quantum technology, we need to reduce these errors by 10,000x. At least.

Riverlane builds QEC tools and technology that correct quantum errors in real-time. It's a complex challenge that requires dedicated and diverse talent. This is where you come in.

You don't necessarily need quantum experience—just a curious mind, a love for solving challenging problems and a desire to make a real impact.

At Riverlane, every day presents an exciting new challenge. Our technical teams collaborate to publish world-changing research and file important patents to help us deliver this ground-breaking technology.

Your work will push the boundaries of what's possible. Together, we'll shape the future of computing.

Are you ready for the challenge?



Apply today!

Check out our current opportunities at [www.riverlane.com/jobs](http://www.riverlane.com/jobs)





## PhD Opportunities in Laser Frequency Combs

The Ultrafast Optics Group is seeking PhD candidates to start by 1 October 2026 on two exciting research projects at the forefront of laser science, astronomical instrumentation and precision optical metrology.

- Laser Frequency Comb Technology for the Extremely Large Telescope
- Advanced Dual-Comb LiDAR: Precision 3D Metrology for Advanced Manufacturing

Both projects are experimentally-led and based in Edinburgh at Heriot-Watt's Riccarton campus.

Applicants meeting UK residency requirements will qualify for stipend and fees funding at the UKRI level.

For further information and application details, visit the Ultrafast Optics Group at Heriot-Watt University:

[www.ultrafast.hw.ac.uk/vacancies.html](http://www.ultrafast.hw.ac.uk/vacancies.html)

Informal enquiries are welcome by email to Prof. Derryck Reid (D.T.Reid@hw.ac.uk)



## C12

### Quantum computing, unique at scale.

#### About us

C12 is a Paris-based quantum computing startup pioneering the next generation of scalable quantum computers. Our approach, carbon nanotube spin qubits, is widely seen as the only viable path to true large-scale quantum computing.

Our international team builds record setting devices and partners with industry leaders to tackle the problems no classical computer can solve.

**€25m+**  
Equity Raised

**25+**  
PhD's

**80+**  
Employees

#### WE'RE HIRING

- 01 Senior Quantum Error Correction Scientist
- 02 Software Engineer
- 03 Customer Delivery Manager

More open roles  
[c12q.com/join-us](https://c12q.com/join-us)



# NTEC

Nuclear Technology Education Consortium  
*Educating the nuclear workforce since 2005*

Register at:



## Nuclear Science and Technology

- MSc - 1 year full time
- MSc - 2 or 3 year part time
- PG Diploma • PG Certificate
- Short Courses for CPD

Designed to create a generation of nuclear engineers and scientists with the skills to secure a sustainable and safe future for nuclear energy.



Key features: Demand-driven • Breadth of learning • Delivered by experts • Flexibility • Short-course format

Choose from a selection of 19 course units, delivered by the Consortium members

For more information:  
visit [www.ntec.ac.uk](http://www.ntec.ac.uk)  
email: [info.ntec@manchester.ac.uk](mailto:info.ntec@manchester.ac.uk) or  
Tel: +44 161 529 4799

# Jumping knots and pointed tips

**Michael Banks** picks his favourite stories and quotes from the weird and wonderful world of physics

Researchers at the University of Pennsylvania and the University of California, Los Angeles, have created a tiny, soft knot-like fibre that can jump metres into the air (*Science* **392** 401). The fibre is less than a millimetre thick and a few millimetres long, and contains a Kevlar core surrounded by a shell of liquid crystal elastomer (LCE). The Kevlar provides strength and stiffness while the LCE adds some flexibility and responsiveness. “People think of a knotted fibre as something passive,” says Shu Yang from the University of Pennsylvania. “But if you design the elasticity and materials carefully, the knot itself becomes an active system.”

When the fibre is knotted it behaves like a spring held in place by a latch, which can be undone via changing the temperature to 60–90°C. The LCE shell contracts and untwists, which loosens the knot just enough to trigger an abrupt untying. All that stored elastic energy then converts into kinetic energy, propelling the fibre almost 2m into the air – a feat comparable to the jumping capabilities of a springtail bug. Changing the knot’s topology and the materials used allows the researchers to tune how the fibre moves after take-off. For example, a simple overhand knot results in a flipping motion while a figure-of-eight knot leads to the fibre spinning.

Inspired by the flight of Maple seeds, the team attached a thin, leaf-like appendage to the fibres, finding that where the wing is positioned on the knot resulted in the fibre landing far away or curving backwards towards its starting position. Given the fibres can be activated with temperature, the researchers think the robot could find applications in agriculture and reforestation. “We often start by exploring interesting phenomena,” adds Yang. “Then we ask how far we can push them and whether they can solve real problems.”

## On point

You might think that a bee’s stinger, a rose’s thorn or a razor-like animal tooth has a sharp pointed tip, rather like “cone-shaped” needles used for injections. Yet a closer look finds otherwise – these objects are usually rounded at the tip, curving gently like a parabola. Why this is the case is a mystery but it was thought that it was the result of convergent evolution, where different species independently arrive at similar solutions. This is partly because a rounded curve penetrates skin better as it distributes forces more evenly throughout the tissue. The rounded shape is also less prone to breaking than a perfect cone.

Physicist Kaare Hartvig Jensen from the Technical University of Denmark (DTU), however, was not convinced by the evolution argument. “There is a general notion that almost everything in nature exists for a reason,” he says. “But if you look at an unused tooth, it does not necessarily have [a rounded] shape, and if you observe the shape later in the organism’s life, the parabola will emerge.” Jensen thought that simple mechanical wear might be behind the effect, and so with his DTU colleague John Sebastian,



Bella Clervo/Penn Engineering

**Tied up in knots** The tiny knotted robot could find uses in agriculture and reforestation.

## Our nations are combining talent and resources in the technologies of tomorrow

**King Charles III**, at a joint session of the US Congress during a state visit to the US in late April, said that new partnerships in areas such as nuclear fusion and quantum computing will help to “ensure that British and American ingenuity continues to lead the world”.

## It’s both exciting and potentially a problem

Particle physicist **Brian Cox** from the University of Manchester says that technologies like AI and quantum computing “are revolutionary”, adding that this represents both a challenge and an opportunity. (Source: *Guardian*)

they went about testing this hypothesis.

Their set-up involved a plate atop a vibrating machine containing several sharpened pencils as stand-ins for their biological counterparts. As the plate vibrated for hours on end, the pencils collided with each other. The team also carried around pencils in a small box in their pockets for several days, again to expose them to random collisions and movements. They found that no matter how sharp the pencils were to begin with, their tips always developed the same rounded parabolic shape (*Proc. Natl Acad. Sci.* **123** e2526098123).

“This points to something more fundamental: that random processes in and of themselves can lead to a universal form,” adds Jensen. “The parabola is a stable shape across scales, from a thorn to an elephant’s tusk. The tips are thus not necessarily designed perfectly from the start – they become so through random wear.” Jensen admits that – rather than in the isotropic case with pencils – most real biological materials have some structure to them, being stronger in one direction than another. “I would like to explore what shapes result from random wear on these structured materials,” adds Jensen. “

**Michael Banks** is news editor of *Physics World*

# Volume Bragg Gratings (VBGs) for Quantum Optics

Available wavelength range: 600-2500 nm  
 Standard Wavelengths: 780; 795; 852; 894 nm  
 Standard Bandwidths: 10; 25; 50 GHz  
 Diffraction Efficiency: > 95%  
 Unmatched side-lobes suppression: > 50 dB

**Parameters of 25-GHz Filter:**  
 Spectral Bandwidth: <25 GHz;  
 Efficiency: >92%;  
 Attenuation: > 30 dB at >150 GHz shift

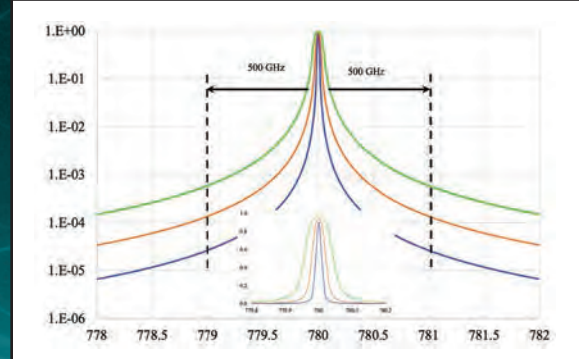
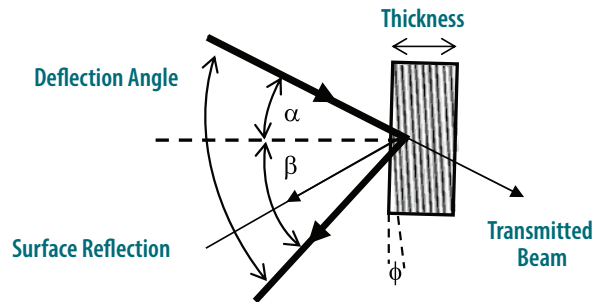

Spectral Shape of Reflecting VBG Filters with Bandwidth: 10 GHz; 25 GHz and 50 GHz

# Chirped Bragg Gratings (CBGs) for Qubit Control

Extremely Large Dispersion  $800 \text{ ps}^2$  enables effective and fast amplitude modulation  
 Spectral Range: 530-2500 nm; High Efficiency > 95%; Wavelength Tunable

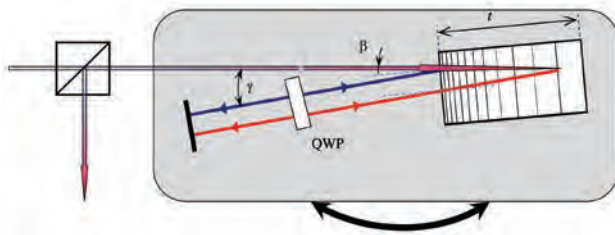

Schematic Diagram of CBG deployment for Qubit Filtering and Control

Group delay dispersion of Chirped Bragg grating (CBG)

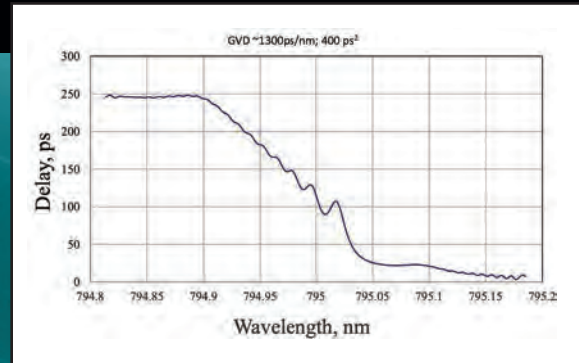

PTR glass based highly dispersive CBGs enabled passively stable, efficient, method of fast amplitude modulation compatible for high power laser sources. [H. Levine et al. "Dispersive optical systems for scalable Raman driving of hyperfine Qubits," Phys. Rev. A 105, 032618 (2022)]

# BLUE FORS

## The Widest Range of Pulse Tube Cryocoolers Available

Enabling a wide array of scientific applications, from particle physics to quantum technology and beyond.

**CRYOMECH**



**Cool for  
Progress.**



### **PT450**

The world's most powerful 4.2 K pulse tube cryocooler.

5.0 W @ 4.2 K w/ 65 W @ 45 K  
(Integrated Motor)

4.5 W @ 4.2 K w/ 60 W @ 45 K  
(Remote Motor)



### **PT425**

Ideal for dilution refrigerators, with options for every need.

2.7 W @ 4.2 K w/ 55 W @ 45 K  
(Integrated Motor)

2.35 W @ 4.2 K w/ 50 W @ 45 K  
(Remote Motor)